



# TRAINING MANUAL



AN INTRODUCTORY GUIDE  
FOR BRIDGE PROJECTS

**LARSA 4D**  
THE COMPLETE SOFTWARE FOR BRIDGES

# LARSA 4D Introductory Training Manual for Steel Bridges

*A manual for*

LARSA 4D  
Finite Element Analysis and Design Software

Last Revised September 17, 2021

Copyright (C) 2001-2024 LARSA, Inc. All rights reserved. Information in this document is subject to change without notice and does not represent a commitment on the part of LARSA, Inc. The software described in this document is furnished under a license or nondisclosure agreement. No part of the documentation may be reproduced or transmitted in any form or by any means, electronic or mechanical including photocopying, recording, or information storage or retrieval systems, for any purpose without the express written permission of LARSA, Inc.

# Table of Contents

<b>Introduction</b>	<b>5</b>
About This Manual	5
<b>Using LARSA 4D</b>	<b>9</b>
Screen Overview	9
LARSA's Terminology	10
Basic Modeling Procedure	10
<b>Getting Started</b>	<b>11</b>
<b>Properties</b>	<b>15</b>
Material Properties	15
Cross-Section Properties	16
<b>Geometry</b>	<b>19</b>
Joints	19
Members	19
Refining the Model	22
Generation Tool and Composite Section	24
Abutments and Piers	31
Second and Third Spans	35
<b>Structure Groups</b>	<b>39</b>
<b>Self-Weight Dead Load</b>	<b>43</b>
<b>Linear Static Analysis</b>	<b>45</b>
<b>Influence Surface Live Load Analysis</b>	<b>49</b>
Preparing the Influence Coefficients: The Surface	49
Preparing the Influence Coefficients: The Load Case	52
Analysis	54
Connecting a Vehicle Database	55
Vehicle Load Setup	55
Live Load Results	58
Finishing Vehicle Loading and Adding Uniform Lane Loading	60
AASHTO LRFD Results	62
Girder Distribution Factors (GDF)	65
<b>Staged Construction Analysis</b>	<b>71</b>
Define Loads On Deck	71
Deck Weight and Wind Load	73
Construction Stages and Steps	75
Include Time Effect on Modulus	79
Running the Analysis	81

Analysis Results	82
Compound Element Forces	85
A Final Note on Code-Based Stresses	88

# Introduction

## About This Manual

This tutorial provides an overview for using LARSA 4D for the analysis of a three-span continuous straight composite steel I-girder bridge.

The example bridge in this guide consists of an I-shape cross-section. It has three spans of 100 feet each. The bearings at the abutments and at Pier 2 are fixed in elevation and transverse directions. The bearings at Pier 1 are fixed in translation in all directions.

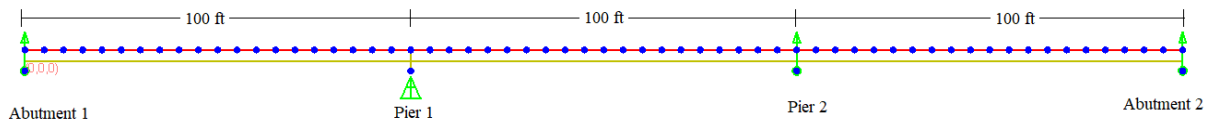

A Three-Span Bridge

The bridge cross-section consists of four girders spaced at 12 feet with 3 feet overhangs. The deck slab thickness is 9 inches.

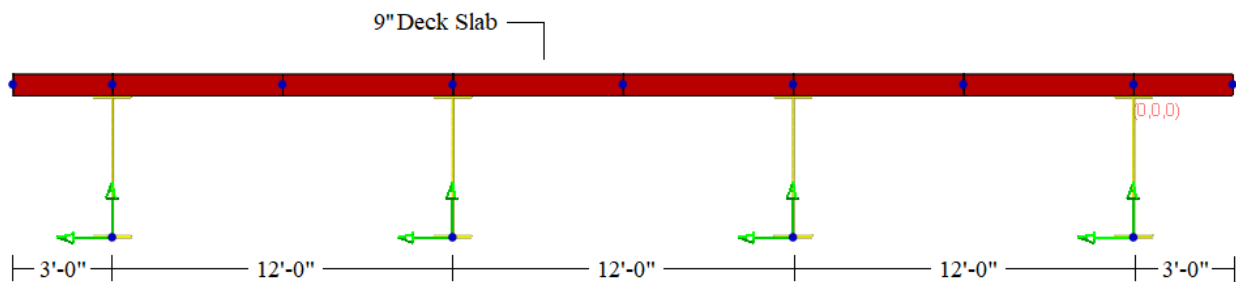

The Cross-Section of the Bridge

The cross-section of the girders is an I-shape as given below:

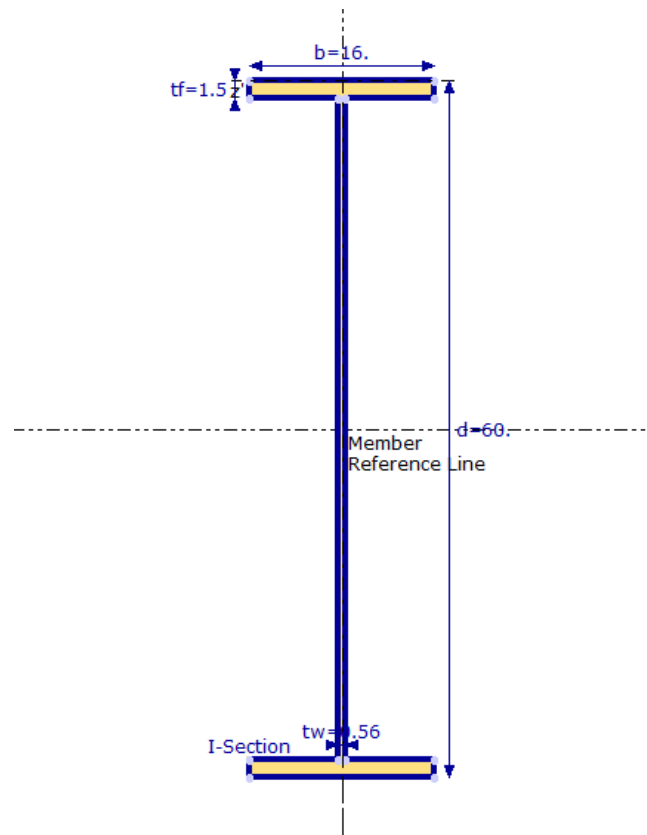

Girder Cross-Section (units: inch)

## Key Concepts

In the first half of this guide we will create the LARSA 4D model by:

- Setting project units
- Importing materials and custom parametric sections
- Creating joints in the spreadsheets
- Drawing members and creating members in the spreadsheets
- Refining the model using Break Members
- Creating shells using the Generation Tool
- Creating bearings using rigid members
- Creating structure groups
- Creating a self-weight load case
- Viewing the results of a linear static analysis with graphical results and results spreadsheets

In the second half of this guide we will cover several analysis techniques:

- Live load analysis for AASHTO LRFD with influence surfaces
- Drawing Loads

- Temporary Loads
- Setting up construction stages
- Time Effect on Modulus
- Staged Construction Analysis
- Compound Element Forces

## About LARSA 4D

LARSA 4D is an advanced multipurpose 3D structural analysis package featuring a powerful graphical user interface and an analysis engine with unmatched analytical features including influence line and surface based live load analysis, staged construction analysis, time-dependent material properties and segmental construction analysis, hysteretic and seismic element and seismic analysis, and progressive collapse.

The LARSA structural analysis engine has been in commercial use for over 25 years. During this time LARSA has become the most trusted software of its kind for segmental, cable-stayed, suspension, steel girder and other bridge forms, as well as other structures requiring advanced staged construction analysis, geometric and material nonlinearity, or complex three-dimensional geometry. With short-span pedestrian to major long-span crossing completed in eight countries and hundreds of cities, LARSA is recognized by leading engineers as the premier software for the design and analysis of today's most iconic structures. We have come a long way since LARSA was first available on VAX super-mini computer decades ago.

LARSA, Inc. has always been an industry leader. LARSA was the first offer an individual PC-based DOS structural analysis package with geometric and material nonlinearity analysis in 1986. In 1994, LARSA took the early next step to Microsoft Windows with a point-and-click graphical user interface and two years later was the first off elastic/perfectly plastic pushover analysis. Today, LARSA's flagship LARSA 4D software products continue to lead the field of bridge software with robust staged construction integrated with nonlinear analysis, influence-surface based live loading, and other complex design needs such as for high-speed rail bridges. Complemented with unique and innovative client support systems, LARSA 4D makes engineers feel comfortable as our developers and support personnel work closely with each client to develop the tools clients need to make their work more efficient and effective.

If you have any questions completing this training manual, you are welcome to contact LARSA's Support Team at [support@larsa4d.com](mailto:support@larsa4d.com).





# Using LARSA 4D

## Screen Overview

The LARSA 4D screen looks like the window in the figure below. In addition to the usual components of a Windows application, like the menu bar and the tool bar, LARSA 4D has a window bar at the bottom of the screen to switch between open windows — such as graphics windows and spreadsheets — and what we call Explorers on the right side of the screen.

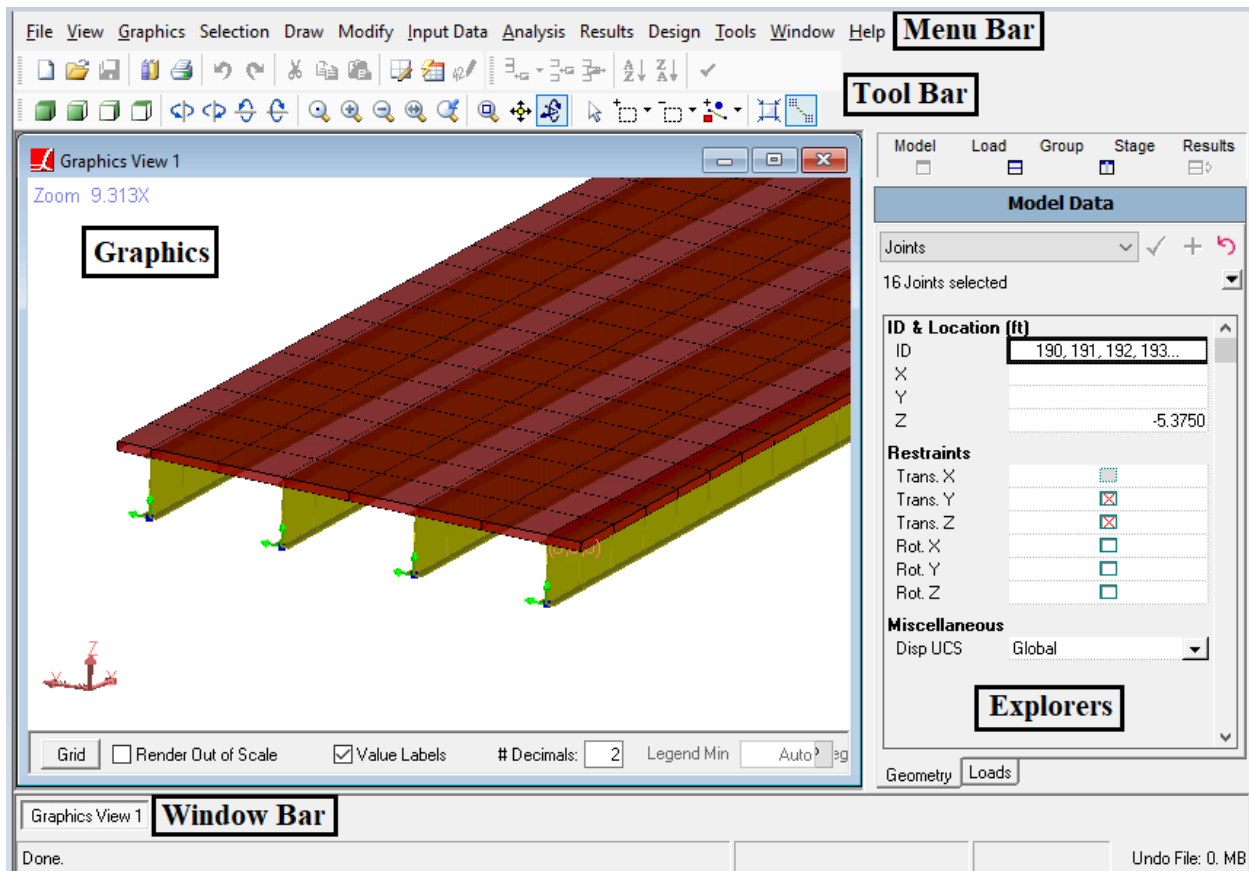

LARSA 4D

The **Input Data** menu on the menu bar is one of the most commonly accessed menus, containing commands for accessing all of the input spreadsheets, importing properties, changing units, connecting databases, etc.

The Explorers are docked on the right-hand side of the screen. The Model Data Explorer is shown above. This explorer is a rapid way of editing the geometry of a project. The other explorers are used to create load cases, structure groups, and construction stages, and to view results.

## LARSA's Terminology

Here are some of the special terms LARSA 4D uses:

- “Properties” refer to the project input that defines the behavior of the elements in the model, including material properties, cross-sectional properties, etc.
- “Geometry” refers to the joints and elements that make up the structure.
- “Joints” are connection points, or nodes, between elements. Joints have 6 degrees of freedom (DOF), three directions in translation and three in rotation.
- “Members” are 2-node elements, including beams and beam-columns, cables and trusses.

## Basic Modeling Procedure

LARSA 4D users normally follow these steps when creating a new model:

- Set project units from **Input Data** → **Units**.
- Import material properties from **Input Data** → **Materials**.
- Import section properties from **Input Data** → **Sections**.
- Create the geometry, either by drawing, using the spreadsheets (**Input Data** → **Geometry**), the Model Data Explorer or Generation Tools.
- Create load cases and load combinations, either using the spreadsheets (**Input Data** → **Load Cases & Combinations**), or the Load Cases Explorer.
- Running an analysis.
- Inspecting results graphically and numerically (**Results** → **Spreadsheets**).

The rest of this manual will illustrate these steps.

# Getting Started

We will now begin the tutorial.

- ☛ Open LARSA 4D, or if LARSA 4D is already open start a new project.
- ☛ Save the project, such as with the name “basic bridge example”.

Units in LARSA 4D come in six categories: coordinates, sections, materials, loads, springs/isolators, mass elements. Each category can make use of different units for convenience. Coordinates are often entered in meters or feet, while sections are often specified in inches or centimeters. The Units window is arranged in a grid, with the unit categories arranged vertically and the unit types (length, force, temperature) horizontally.

- ☛ Set the units to be used in the project with the **Input Data** → **Units** command.

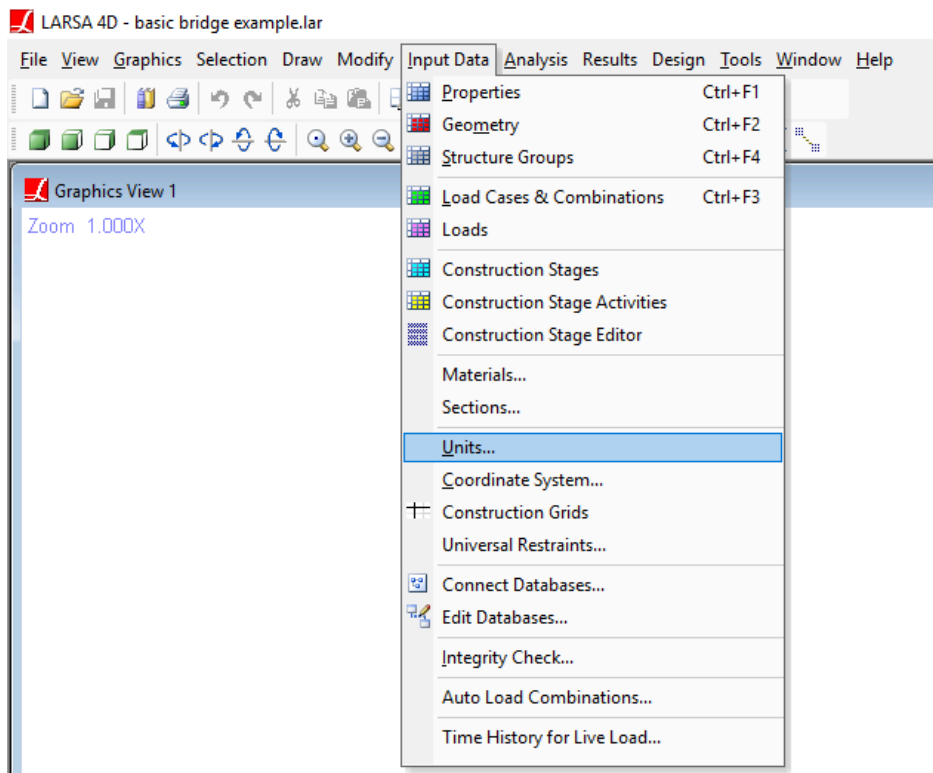

Input Data Menu

The units should be as indicated in the figure below.

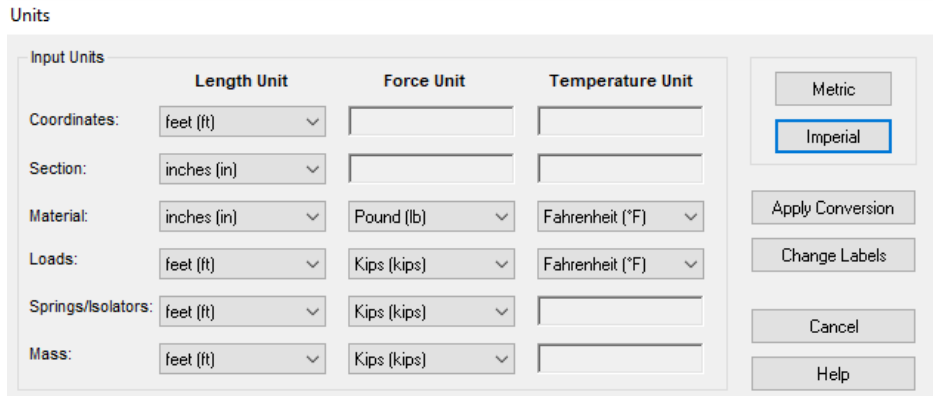

Units

*Apply Conversion* converts all numeric values in the project to the new units you have specified. Since we have not entered any data yet, we will use *Change Labels* to set the project's units without applying a unit conversion.

- ◆ Click **Change Labels** button.
- ◆ Set up initial visual display options in the **Graphics** → **Show** command, which controls which aspects of the project model are included in the graphics view. Be sure Joints, Members, Shells, Lanes, and Supports under Display Objects are turned on.

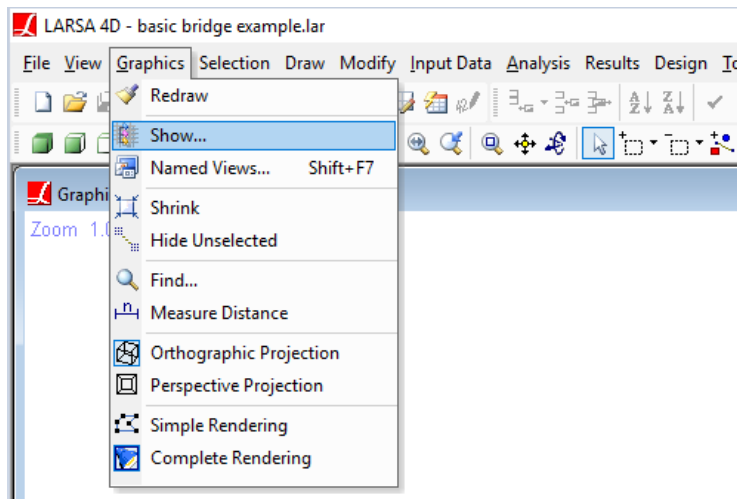

Graphics Menu

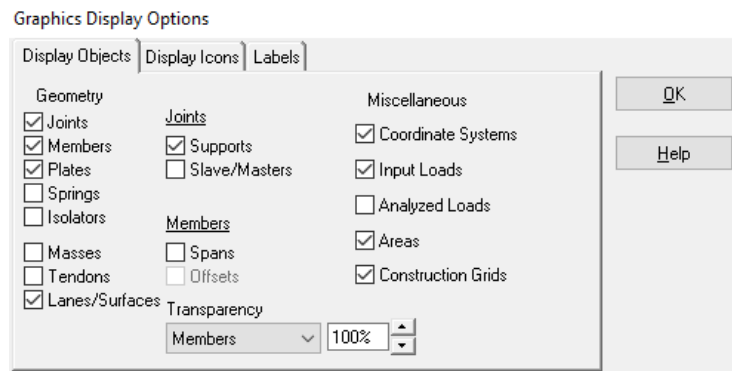

The Show Command



# Properties

Before starting on the geometry of the project, we will bring in material and section properties to assign to the girder and the deck.

## Material Properties

☛ In the **Input Data** menu, choose the **Materials** tool. It is shown below.

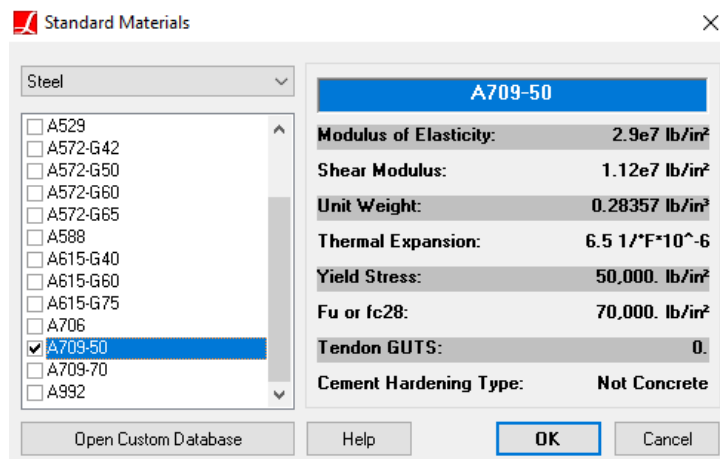

Importing Standard Materials

The materials tool presents a database of common material properties. They are not available for use until they are imported into the project.

- ☛ Select the Steel category and choose a steel material appropriate for the girders, such as A709-50. Click the material so it is checked.
- ☛ Change to the Concrete category and choose a material appropriate for the deck, such as Fc\_4. Click the material so it is checked.
- ☛ Click **OK** to import the materials.
- ☛ Go to **Input Data** → **Properties** and review the materials added to the project.

The screenshot shows a software window titled "Properties: Material Properties" with several tabs: Materials, Sections, UCS, Spring Properties, Isolator Definitions, Material Time Effects, and Temperature Curve. The "Materials" tab is active, showing a table with columns for Name, Modulus of Elasticity (lb/in<sup>2</sup>), Poisson Ratio, Shear Modulus (lb/in<sup>2</sup>), Unit Weight (lb/in<sup>3</sup>), Thermal Expansion (1/°F), and Assigned. There are three rows of material data.

	Name	Modulus of Elasticity (lb/in <sup>2</sup> )	Poisson Ratio	Shear Modulus (lb/in <sup>2</sup> )	Unit Weight (lb/in <sup>3</sup> )	Thermal Expansion (1/°F)	Assigned
1	A709-50	29,000,000.	0.2946	11,200,000.	0.2836	6.500000	No
2	Fc_4	3,605,000.	0.1697	1,541,000.	0.0868	5.500000	No
3							

At the bottom of the dialog, there is a checkbox labeled "Show Only Selected Objects" which is currently unchecked.

Materials Spreadsheet

## Cross-Section Properties

We will use a parametric cross-section shape for the I-section, which comes in LARSA 4D's custom section shape library.

- ☛ Go to **Input Data** → **Sections**.
- ☛ Click the **Custom** tab.
- ☛ Find the I Beam group, expand the group by double-clicking it, and choose Symmetrical I-Beam.

The shape is customized by setting its name and four dimension parameters.

- ☛ Set the name and parameters according to the figure below.

Standard / Custom Sections

The screenshot shows the "Standard / Custom Sections" dialog box. The "Custom" tab is selected. On the left, a tree view shows various section types, with "I Beam" expanded to show "Symmetrical I-Beam". The "Section Name" field is set to "Girder I-Section". Below it, a table lists parameters for the "Symmetrical I-Beams":

Parameter	Value
d	60.00
b	16.00
tf	1.000
tw	0.560

On the right, a diagram of the I-beam section is shown with dimension lines. The depth is labeled "d=60", the flange width is "b=16", and the flange thickness is "tw=0.56". The section is oriented with "Member +Y" horizontal and "Member +Z" vertical. The diagram also shows the principal axes "pyy", "lyy", "lzz", and "pzz".

Importing a custom I-shape section



Click **Import** to bring the section definition into the project.

LARSA 4D will ask whether it is OK to create a new parametric section database for the model in which to put the section definition.

Click OK and save the file along with your project. You may use the file name “basic bridge example sections”.

Go to **Input Data** → **Properties** and change to the **Sections** tab.

You will see that the Girder I-Section is added to the project.

Because the torsion constant can take a long time to compute, it is zero by default.

To calculate the torsion constant for the section, right click the row of this section definition in the spreadsheet and select **Calculate Properties**.

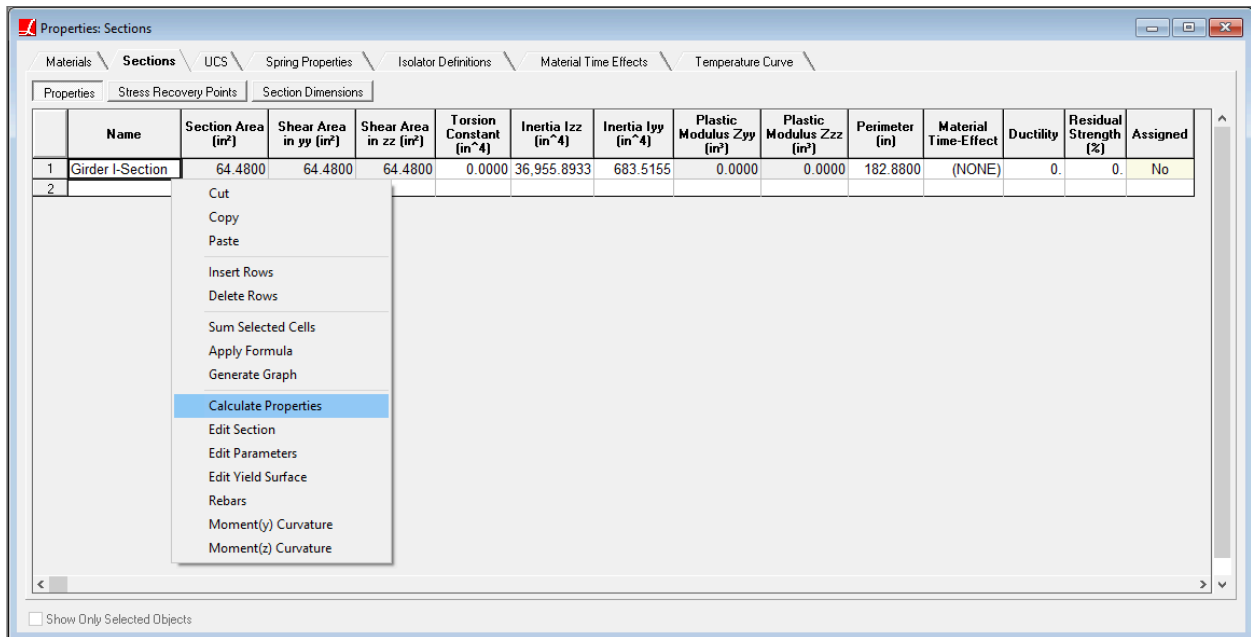

Sections Spreadsheet

For More Information, please refer to the following documentation.

- Properties in *LARSA 4D Reference Manual*.



# Geometry

Because this model is of a straight bridge, we will lay out the geometry along the global x-axis starting at 0. The piers will be at 100 feet and 200 feet. The final abutment will be at 300 feet. The elevation axis will be the global z-axis.

There are several ways to enter geometry in LARSA 4D: using spreadsheets, the Model Data Explorer, drawing the geometry graphically with the mouse, the generation and transformation tools, and importing geometry from other programs such as Excel or CAD software. We will start by using the spreadsheets in this tutorial.

Model geometry in this tutorial consists of three types of objects: joints, members, and shells. Joints represent connection points between elements and have six degrees of freedom. Members are two-node line elements. They will be used to represent the girder. Shells are planar elements with constant thickness, either triangular or quadrilateral in shape, with isotropic material properties. They have both plate bending (out-of-plane action) and plane stress (membrane actions, in-plane action) stiffness.

## Joints

We will begin the model by creating the first span. After we complete the first span, we will use generation tools to clone it into the second and third spans.

- ☛ Open the geometry spreadsheets using **Input Data** → **Geometry**. The Joints spreadsheet is the first spreadsheet that opens in the Geometry group.
- ☛ In the blank row, enter the coordinates (0, 0, 0). After the first value is entered, the row becomes initialized as a joint.

Spreadsheets always have a final blank row which is used to enter more data.

- ☛ Repeat this to enter another joint at (100, 0, 0).

	ID	X (ft)	Y (ft)	Z (ft)	Translation DOF	Rotation DOF	Displacement UCS	Assignment
1	1	0.0000	0.0000	0.0000	all free	all free	Global	No
2	2	100.0000	0.0000	0.0000	all free	all free	Global	No
3								

Joints Spreadsheet

## Members

To create the girder, it is also possible to use a spreadsheet. We will instead use the drawing tool to show more of the capabilities of LARSA 4D.

- ☛ Change to the **Graphics View** window by clicking the window button at the bottom of the screen.
- ☛ Click the **Zoom Extents** tool on the tool bar to properly position the joints on the screen.

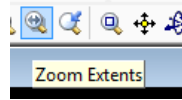

Zoom Extents

The drawing command allows us to click the joints where members should go.

- ☛ In the **Draw** menu, activate **Geometry** → **Members**.

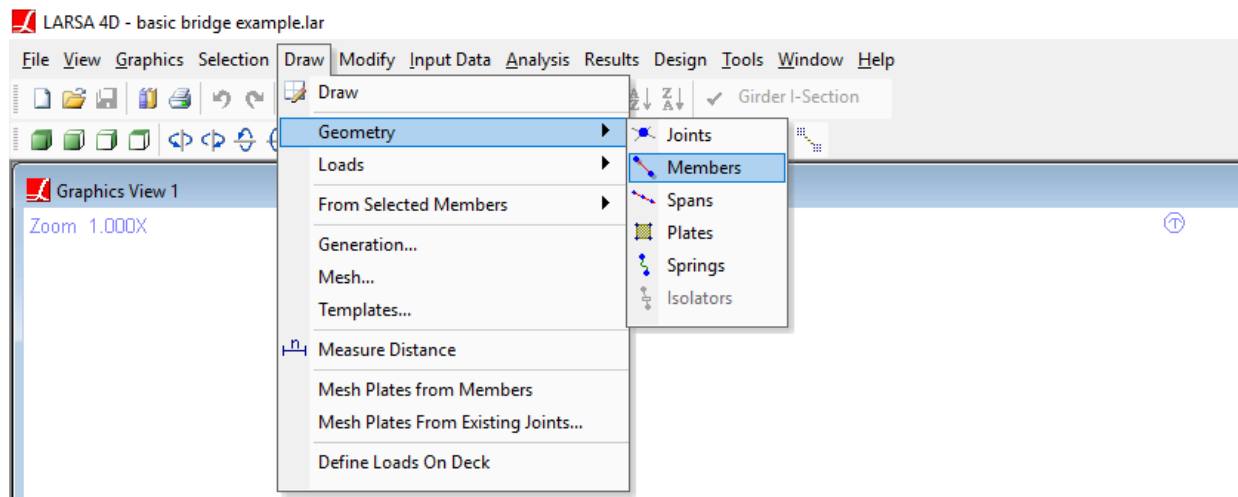

Draw Menu

- ☛ In the Model Data Explorer on the right-hand side of the screen, choose the appropriate section (“Girder I-Section”) and material (“A709-50”) for the girder under the **Properties** heading. Also set orientation angle to 90 degrees, which is the usual convention for horizontal members.

No other fields in the Model Data Explorer need to be set now.

- ☛ Click the left joint (and then release the mouse button) to start drawing a member from that joint. Then click the right joint to complete drawing the member for the first span.

The member is created with the section, material, and orientation angle we chose.

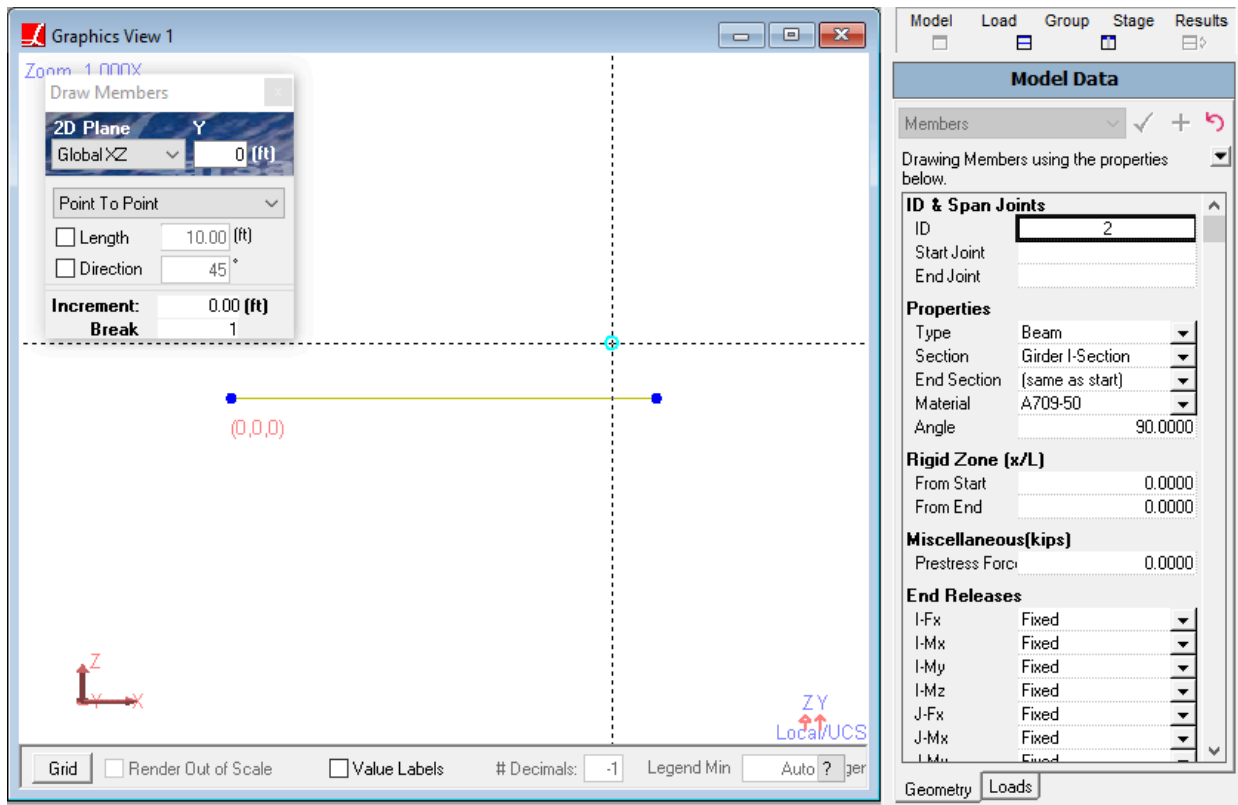

Drawing Members

- ☛ To end the drawing operation, close the floating Draw Members window by clicking on its X close button.
- ☛ Check that the member has been set up correctly by going to the geometry spreadsheets using **Input Data** → **Geometry**. The Members spreadsheet is the second spreadsheet that opens in the Geometry group.
- ☛ Return to Graphics View 1 window. Go to **Graphics** → **Complete Rendering** to view the model in complete rendering. You may want to use the graphics rotation tools to get a better view.

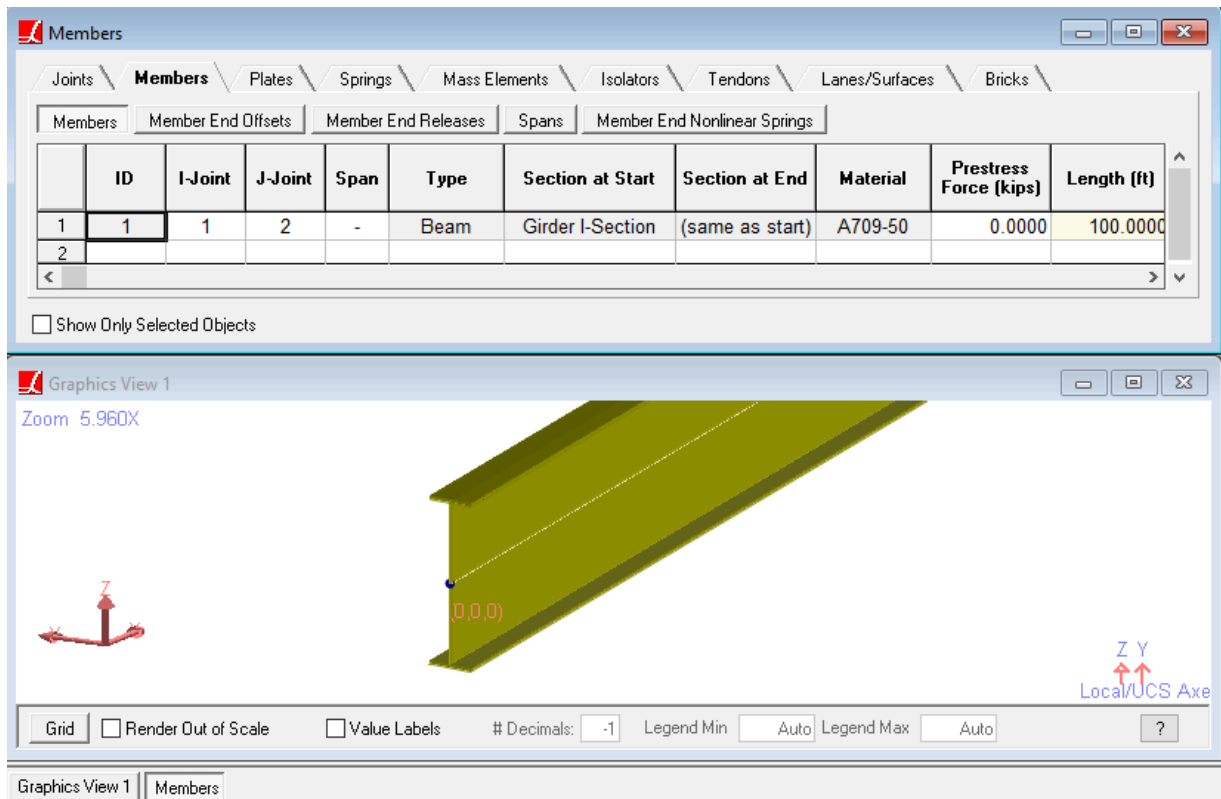

Members spreadsheet and complete rendering of the model

- ☛ Turn off complete rendering using **Graphics** → **Simple Rendering** and if necessary return the graphics view to side view by clicking Front Plane button on the toolbar.

## Refining the Model

We will break members before adding other girder members and the deck to the model.

Before running an analysis, it is important to break up long member elements into small pieces. Displacements are computed only at the locations of joints in the model, so it is necessary to put joints at intermediate locations on each span.

We will use the Break Members tool to break the existing member into smaller pieces. The Break Members tool operates on selected geometry (only).

- ☛ Go to **Modify** → **Break Members**.

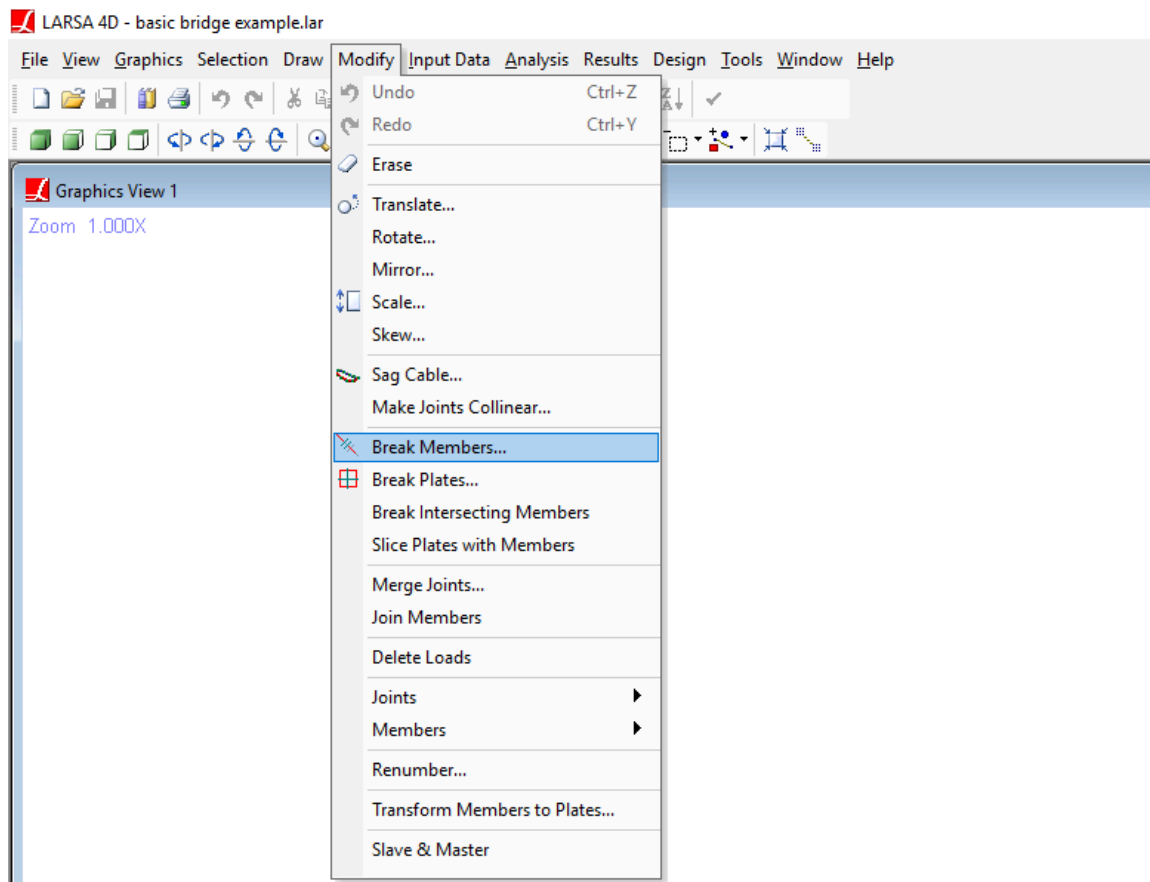

Modify Menu

Enter 20 for the number of segments and then click **OK**.

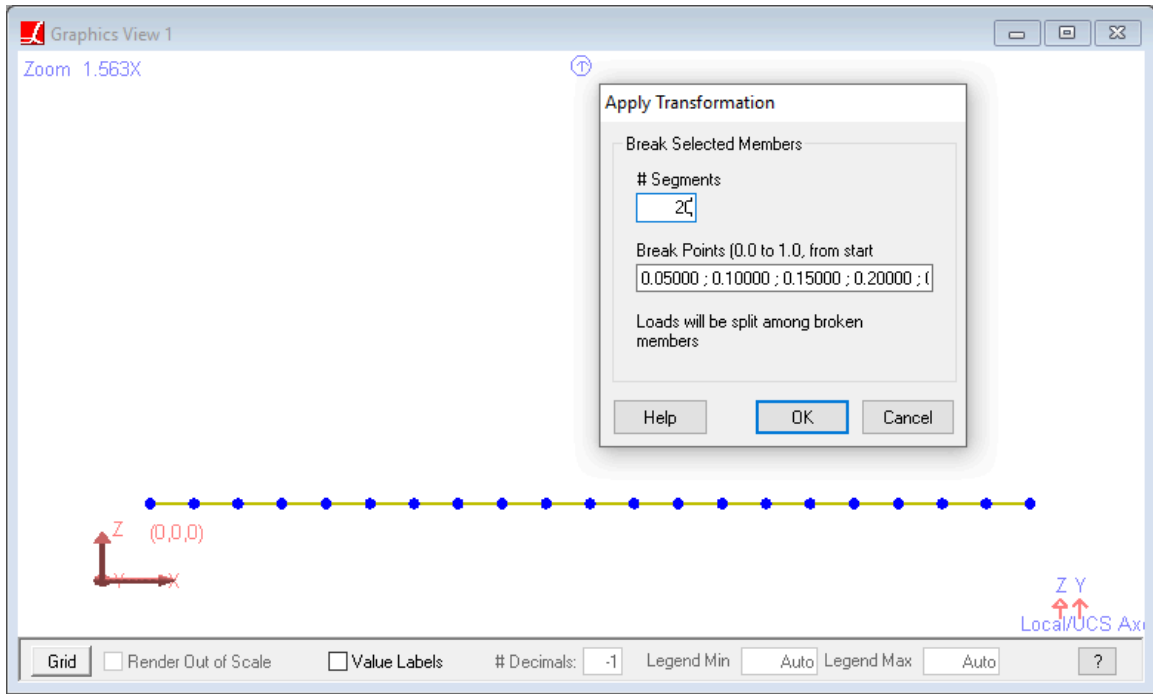

Breaking Members

By breaking the span into 20 segments with 5-foot segment length, we make it possible to create cross frames, girder section transitions, and other things that align with that interval. For example, if there is a cross frame every 15 feet, a 5-foot segment length will be convenient for adding cross frames.

## Generation Tool and Composite Section

We will generate the model using generation tools which quickly generate new structural elements by copying, extrusion, and meshing.

The below figure shows the procedure that we will follow. First, we will use the Extrusion command to extrude the existing member into shells that make up the deck. Then, we will use the extrusion command second and third times to generate deck overhang shells. Finally, we will use the Repeated Copy command and generate other spans by copying the first span.

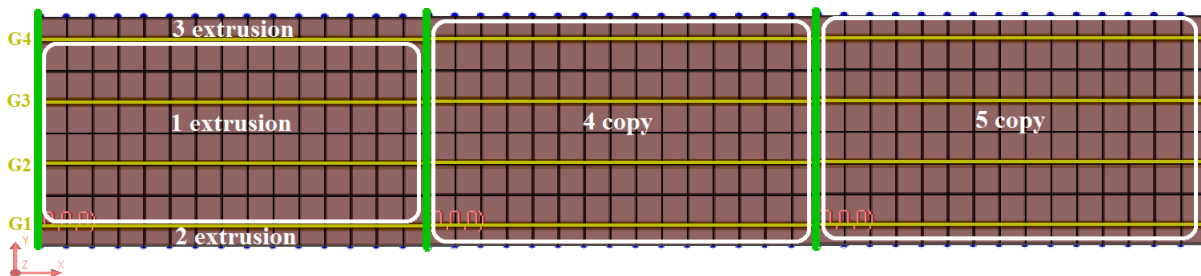

Generation

☰ Open the Generation Tool using **Draw** → **Generation**.



- ☛ Select the **Extrusion** command by clicking on its name in the listing on the left of the window.

Extrusion will extrude selected joints into members or selected members into shells along the given direction, by also repeating the joints or members. Since we have 12 ft girder spacing, we can use 3 repetitions to generate 4 girders and the shells in between. Instead of this, we will use 6 ft spacing with 6 repetitions in order to mesh deck shells. As a result, some extra members will be generated but we will remove them from the model afterwards.

- ☛ Select element type as Shells (and make sure Members is unchecked), enter Delta Y as 6 ft with 6 repetitions.

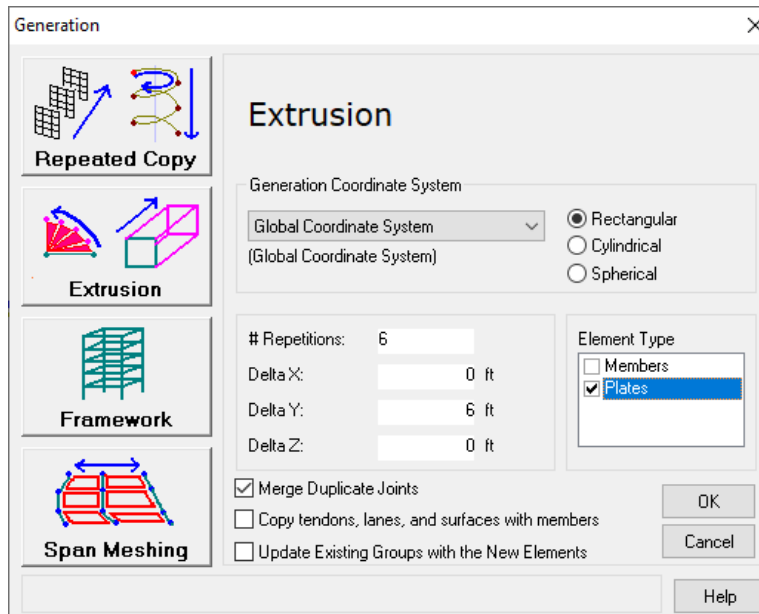

Generation Tool - Extrusion

- ☛ Switch to top view by clicking Top Plane on the toolbar. Press **N** twice in order to see the member IDs and verify that vertical lines do not have a number. After verifying, keep pressing **N** until the numbers disappear.

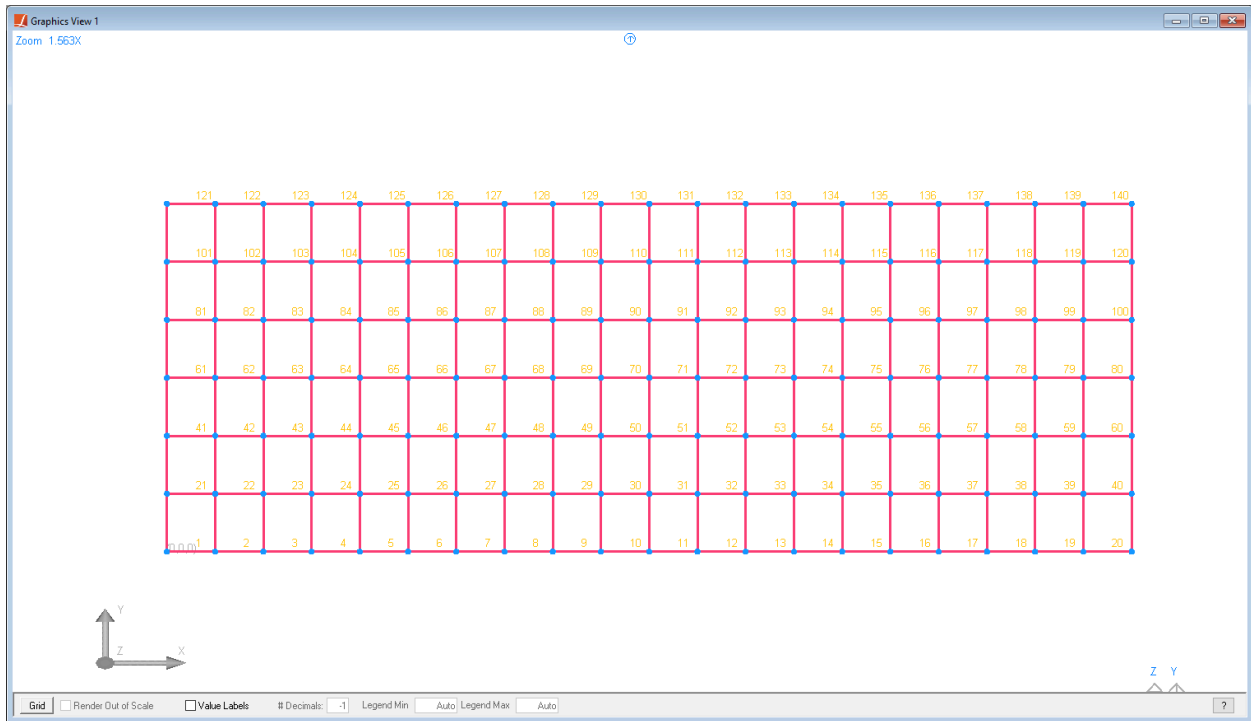

### Extrusion

Now we will extrude the exterior girders to create shells for the overhang.

☛ Unselect all elements using **Selection** → **Unselect Objects** → **Unselect All**.

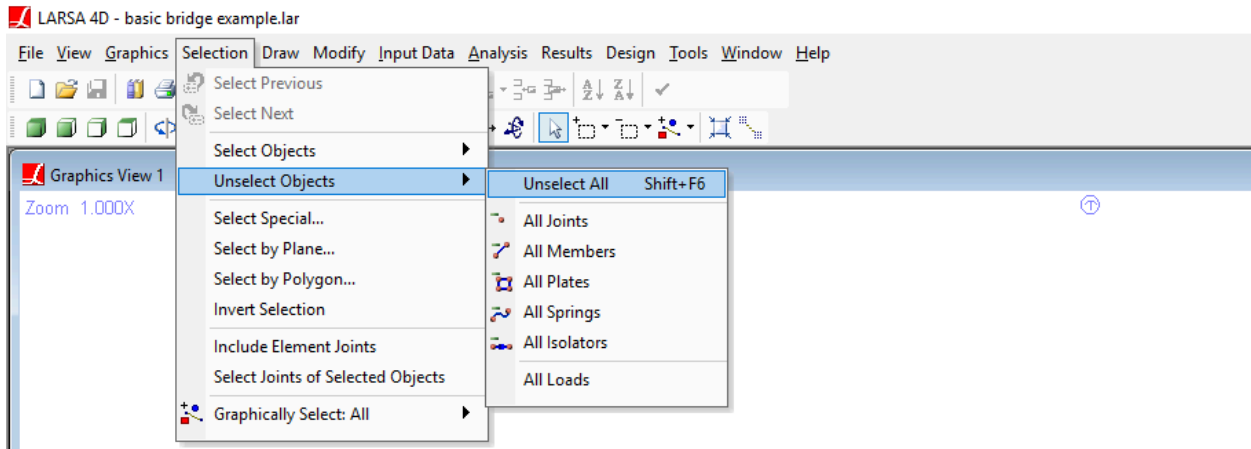

### Selection Menu

☛ Using the toolbar, activate the graphical selection tool.

The mouse can now be used in the graphics window to select elements.

☛ Click-and-drag a window around the first girder to select the joints and members that make up the girder.

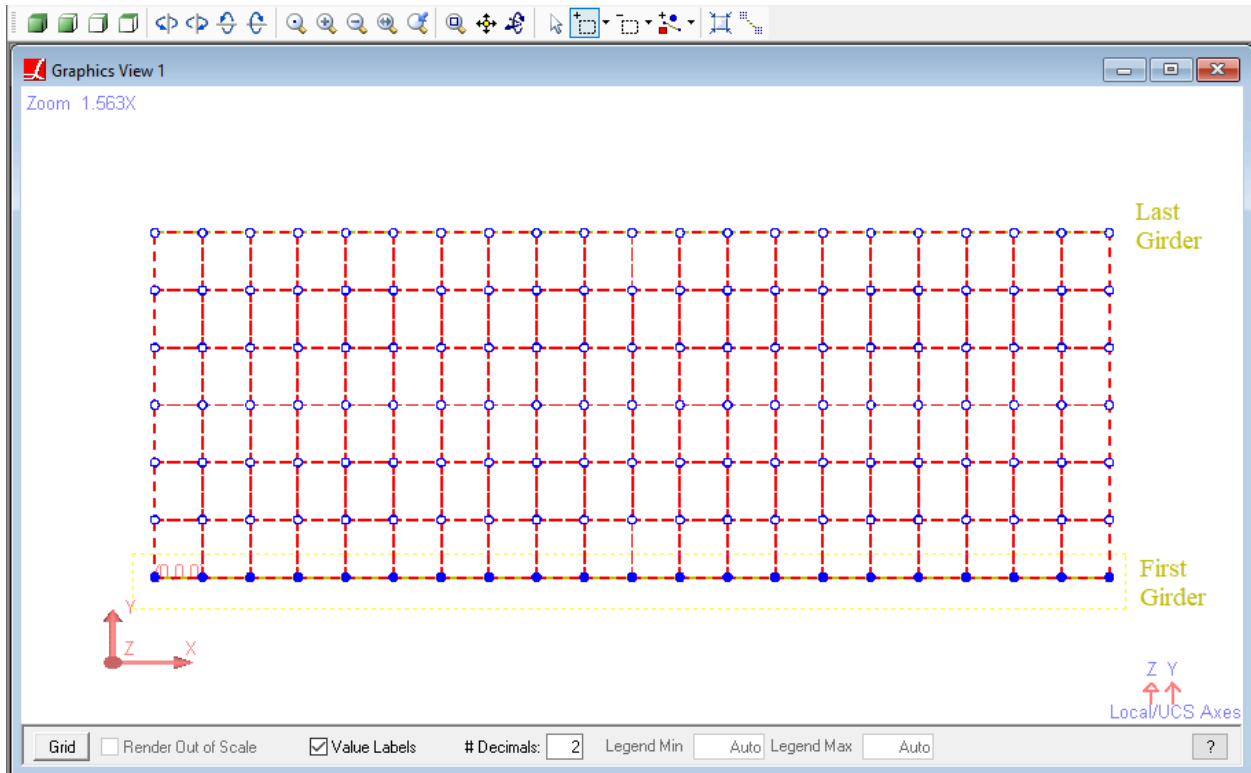

Select Graphically

Like in other CAD software, drawing windows from right to left and from left to right are different. If you drag from right to left, make sure you do not include any other girder in your selection window. If you drag from left to right, make sure all of the girder is contained within the window you draw.

- ◆ Open the Generation Tool again and extrude the selected member by entering Delta Y as -3 ft with 1 repetition (make sure Members is unchecked).
- ◆ Unselect all elements and repeat the same procedure for the last girder by entering Delta Y as 3 ft.
- ◆ After extrusion, select all elements using **Selection** → **Select Objects** → **Select All**.
- ◆ Using the toolbar, change graphics view to the Side Plane, and turn on Local Axis icons from **Graphics** → **Show** → **Display Icons**.

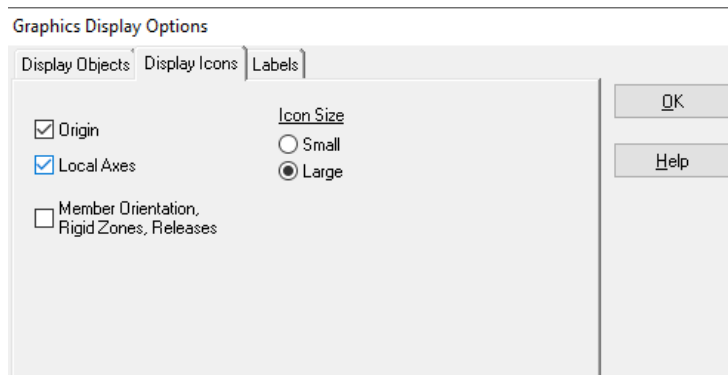

Turn on Local Axes in Graphics Display Options

The local axes of shells that are extruded in -Y direction are different from the others.

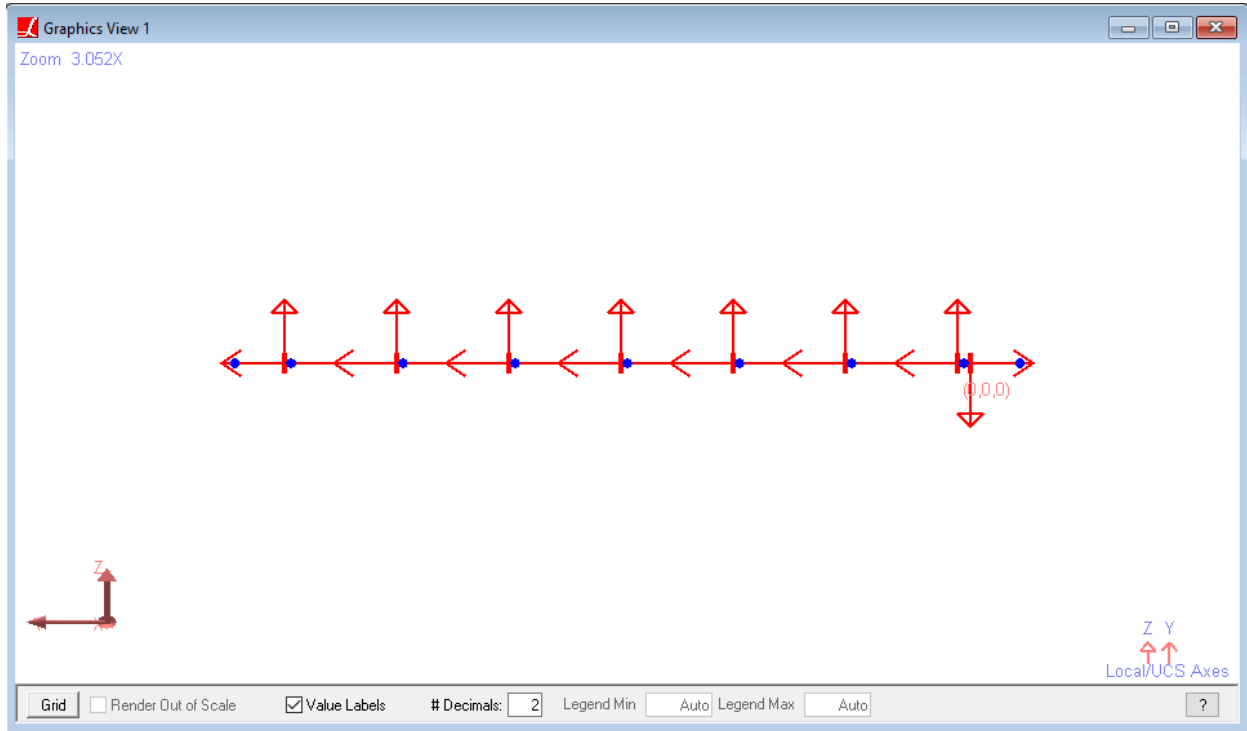

#### Local Axes of Shells

- ☛ Go to **Modify** → **Shells** and choose **Put Local Axes in Same Direction**.
- ☛ After seeing the local axes in the same direction in the graphics view, turn off local axes icons in **Graphics** → **Show** → **Display Icons**.
- ☛ Go to **Input Data** → **Geometry** → **Shells** to open the shells spreadsheet.
- ☛ Click the column header for the Thickness column to select the entire column.
- ☛ In the spreadsheet edit tool in the toolbar, which we call the Edit Bar, enter 9 inches, then click the checkmark to apply the change to the selected cells.
- ☛ Using a similar process, set the material of all of the shells to Fc\_4.

At this step, the extra members that are generated as a result of repetitions can be clearly seen in the Complete Rendering.

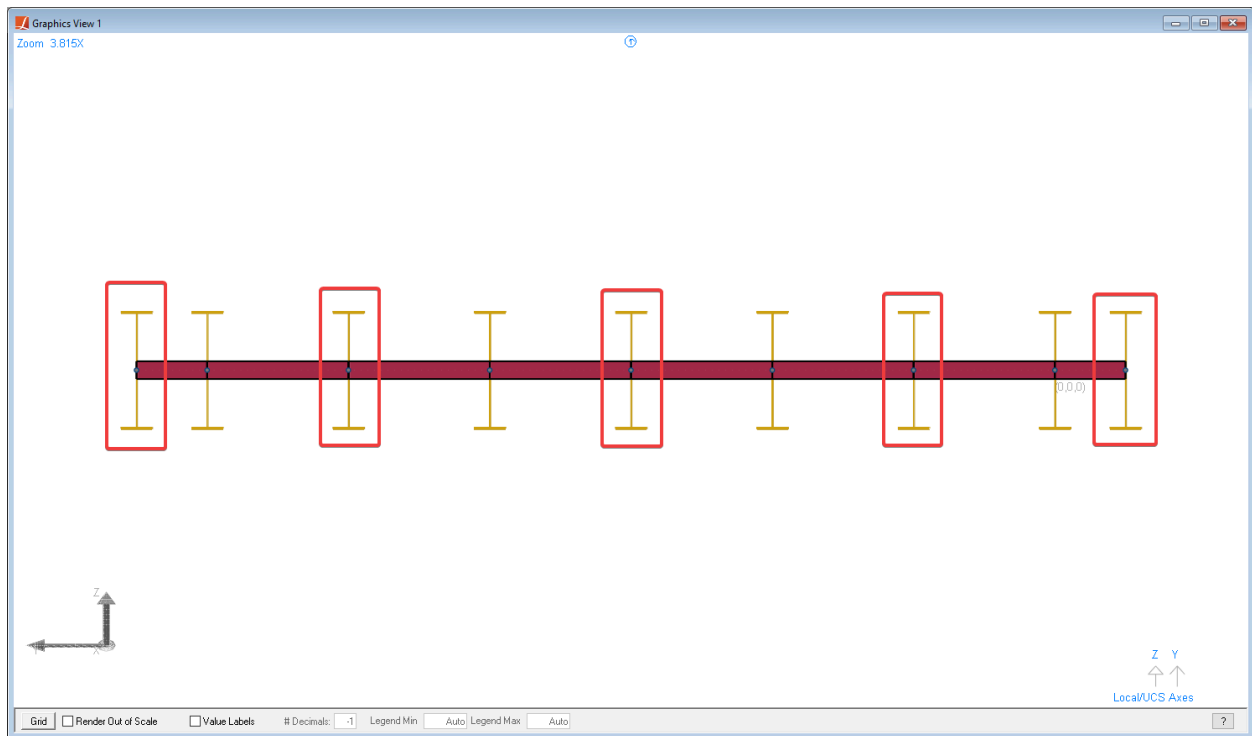

Extra Members in Complete Rendering

- ☛ Using the selection tools in the menu, unselect all elements. Then using the graphical selection tool, select the extra members graphically. Go to **Modify** and **Erase** the selected members. A total of 100 members should be deleted.

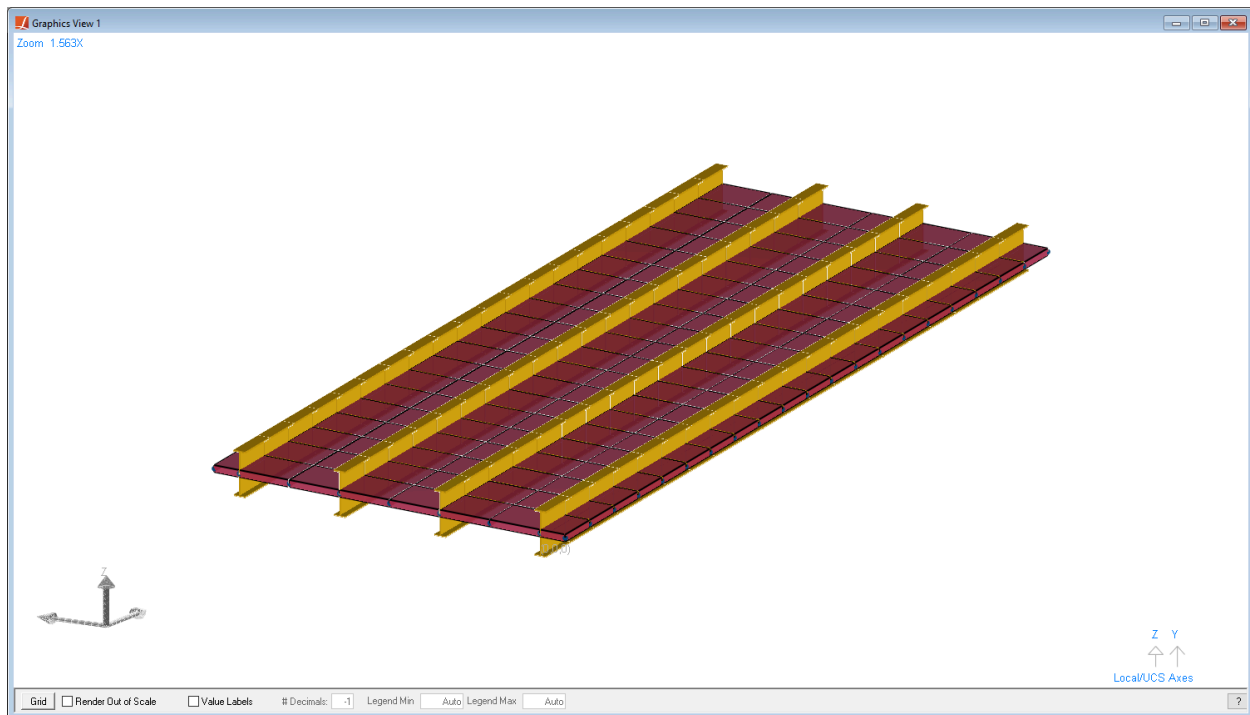

Model After Deleting Extra Members

The last step for modeling the girders and deck is using member end offsets to position the centroid of the girder members half of the girder depth plus half of the deck thickness below the centroid of the deck shell elements.

- ☛ Go to **Input Data** → **Geometry** → **Members** and switch to **Member End Offsets** tab.
- ☛ Click on the I-Offset Z column header to select all cells in the column. In the Edit Bar in the toolbar, enter -2.875 ft, and then click the checkmark to update the selected cells. Do the same for J-Offset Z column.

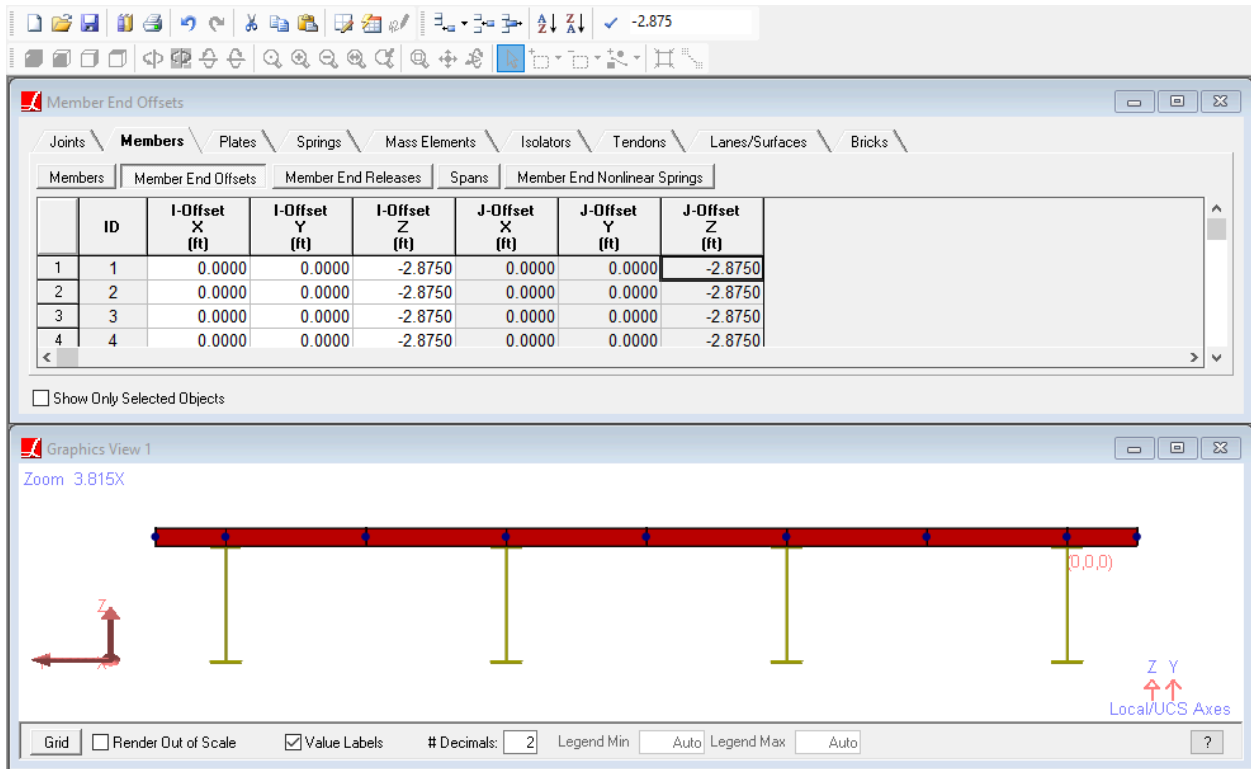

Member End Offsets

## Abutments and Piers

To model the actual location of bearings at abutments and piers, joints will be created at the bottom of the girders. Rigid members will be added between the center of the deck and the new bearing joints.

We will create a new material sharing similar properties with girder steel and also a new section with section properties 10 times larger than the girder section (When creating a rigid section, making its properties 10 times larger than or even equal to the largest section present is usually sufficient). These properties will be used to create rigid line elements. Note that the Unit Weight of the rigid material is zero so that LARSA 4D does not automatically apply any self weight loading for those elements.

Go to **Input Data** → **Properties** and enter properties as seen in the below figure.

Properties: Material Properties

Materials / Sections / UCS / Spring Properties / Isolator Definitions / Material Time Effects / Temperature Curve

Basic Properties / More Properties / Orthotropic Properties

	Name	Modulus of Elasticity (E) (lb/in <sup>2</sup> )	Poisson's Ratio	Shear Modulus (G) (lb/in <sup>2</sup> )	Unit Weight (lb/in <sup>3</sup> )	Thermal Expansion (1/ °F *10 <sup>-6</sup> )	Assigned
1	A709-50	2.90e7	0.2946	1.12e7	0.2836	6.500000	Yes
2	Fc_4	3,605,000.00	0.1697	1,541,000.00	0.0868	5.500000	Yes
3	Rigid Material	2.90e7	0.2946	1.12e7	0.0000	0.000000	Yes
4							

Rigid Material

Properties: Sections

Materials / Sections / UCS / Spring Properties / Isolator Definitions / Material Time Effects / Temperature Curve

Properties / Stress Recovery Points / Section Dimensions

	Name	Section Area (in <sup>2</sup> )	Shear Area in yy (in <sup>2</sup> )	Shear Area in zz (in <sup>2</sup> )	Torsion Constant (in <sup>4</sup> )	Inertia Izz (in <sup>4</sup> )	Inertia Iyy (in <sup>4</sup> )	Plastic Modulus Zyy (in <sup>3</sup> )	Plastic Modulus Zzz (in <sup>3</sup> )	Perimeter (in)	Material Time-Effect	Ductility	Residual Strength (z)	Assigned
1	Rigid Connection	644.8000	644.8000	644.8000	133.9420	3.6955e5	3.6955e5	0.0000	0.0000	0.0000	(NONE)	50	0	Yes
2	Girder I-Section	64.4800	64.4800	64.4800	13.3942	36.9558933	683.5155	0.0000	0.0000	182.8800	(NONE)	0	0	Yes
3														

Rigid Section

Switch back to Simple Rendering. Unselect all elements, and then select the joints at the beginning and end of the girders.

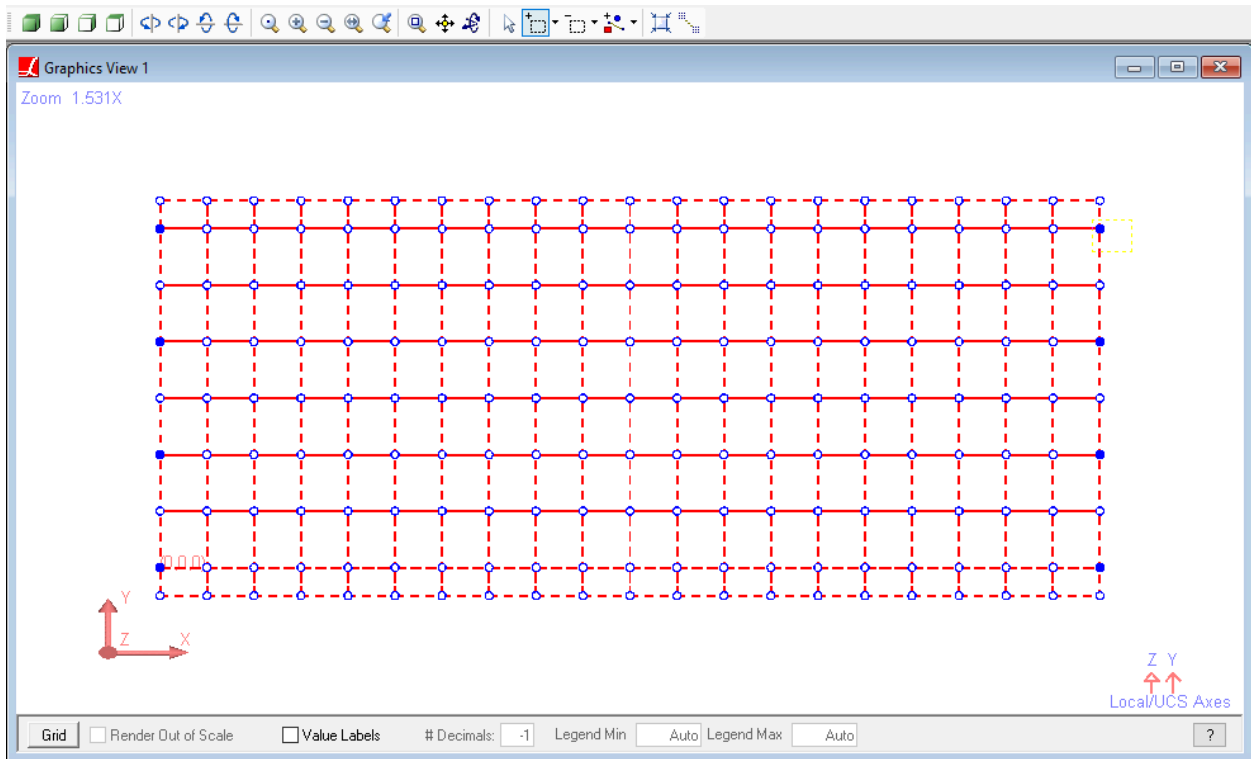

Bearing Locations



- ☛ Go to **Input Data** → **Geometry**, and in the Joints spreadsheet check the Show Only Selected Objects checkbox below the spreadsheet.
- ☛ Copy the coordinates of the eight selected joints. Then uncheck the Show Only Selected Objects checkbox.

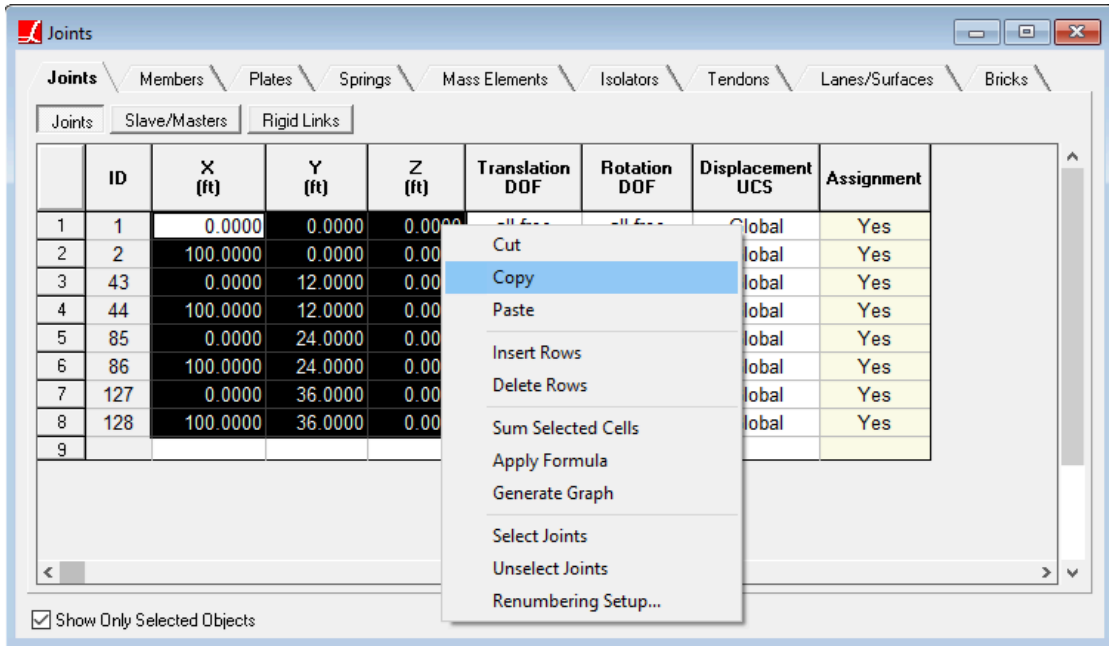

Copy Data From Spreadsheet

- ☛ Paste the coordinates into the last row of Joints spreadsheet. Using the Edit Bar in the Toolbar, update the Z coordinate of the new joints to -5.375 (that is the half of the deck thickness plus the girder depth).

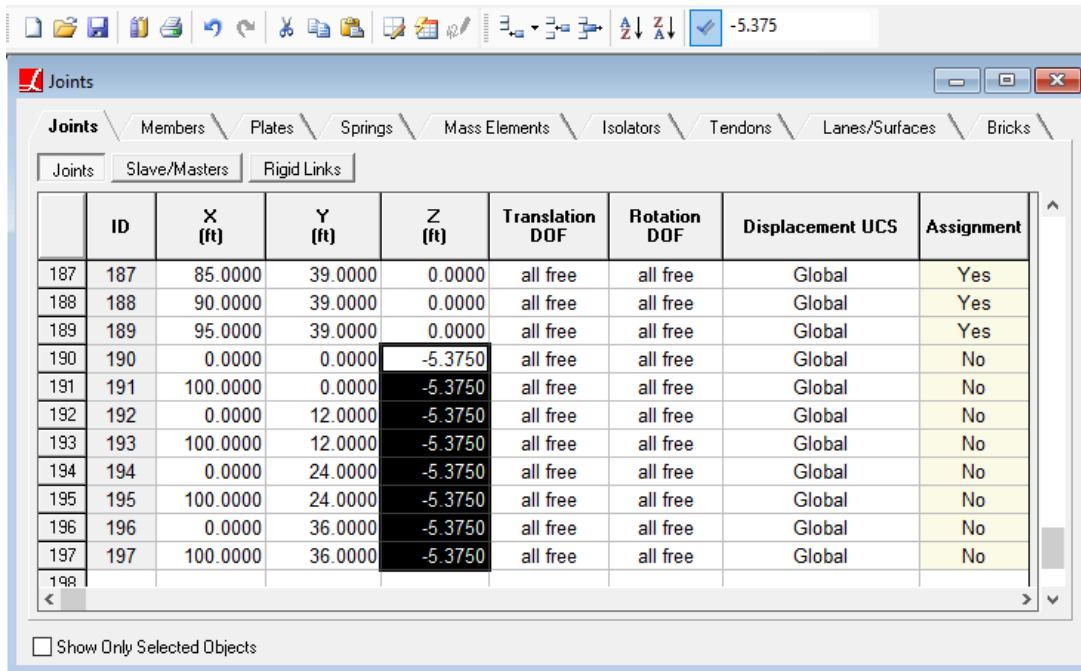

Using the Edit Bar

- ☛ Change to the **Graphics View** window, and click the graphics toolbar buttons for 3D View and activate **Graphics** → **Hide Unselected**.
- ☛ In the **Draw** menu, activate **Geometry** → **Members**.
- ☛ In the Model Data Explorer on the right-hand side of the screen, choose the appropriate section (“Rigid Connection”) and material (“Rigid Material”) for the rigid member.
- ☛ Draw eight rigid members from the joints on the girders to the new joints below the girders where the bearings will be placed.

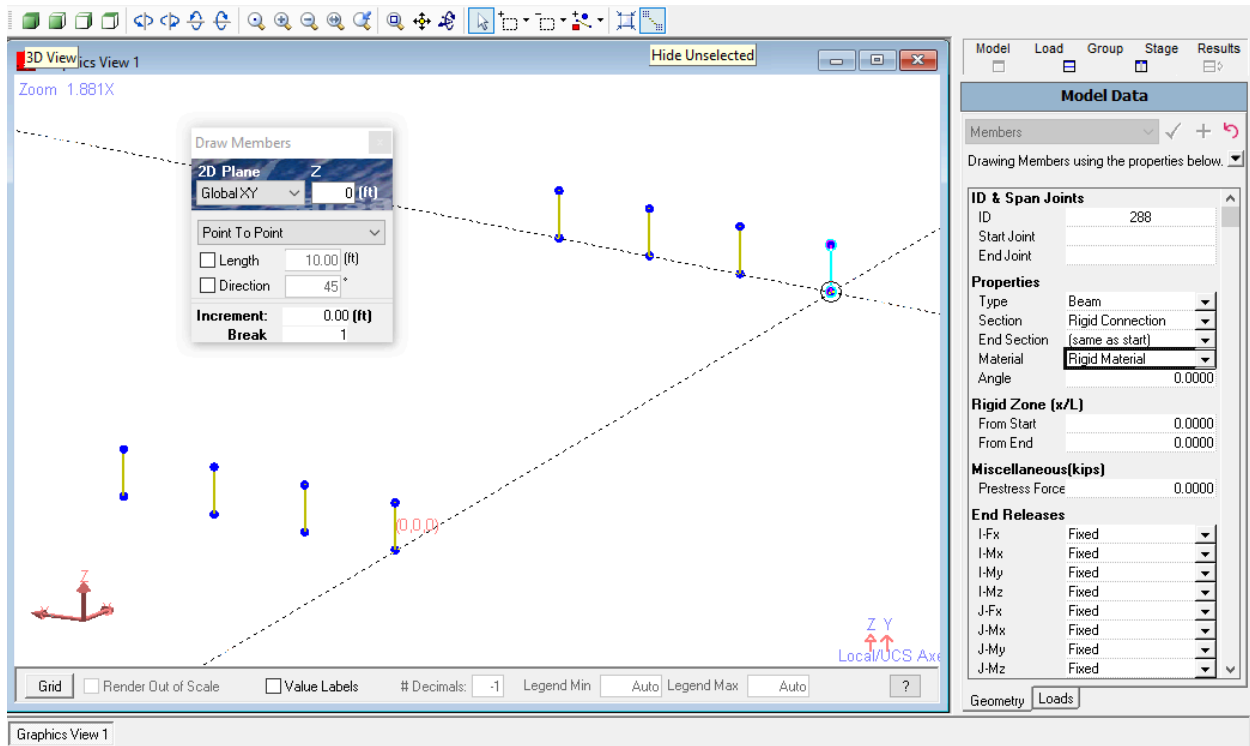

Rigid Members

- ☛ To end the drawing operation, close the floating Draw Members window by clicking on its X close button.
- ☛ Deactivate **Graphics** → **Hide Unselected** to show all elements and using the selection tool or the keyboard shortcut **S**, select all elements.

## Second and Third Spans

Next we will use the Generation Tool to make copies of the first span, which will become the second and third spans.

- ☛ To avoid the generation of overlapping members, switch the view to Front Plane and unselect the rigid members on the left.

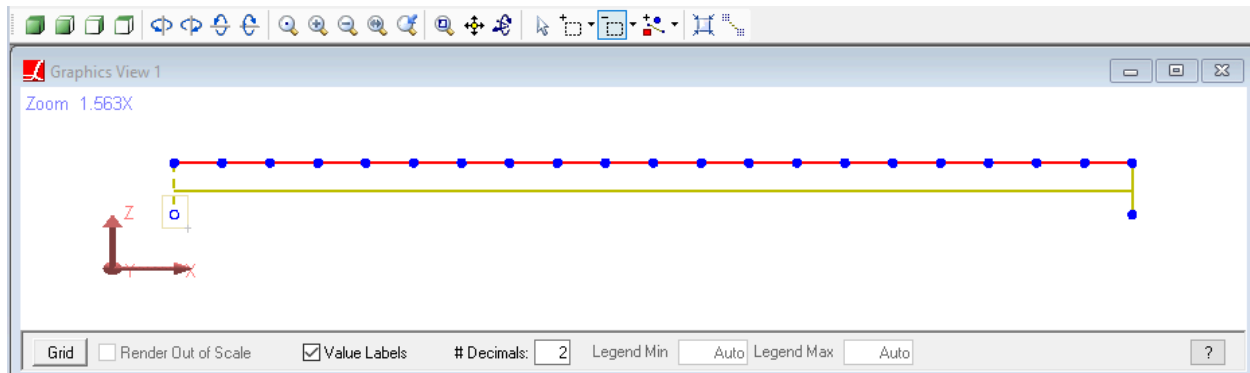

Avoid Overlapping Members

- Open the Generation Tool using **Draw** → **Generation**. Select the Repeated Copy command, enter Delta X as 100 ft with 2 repetitions and click OK.

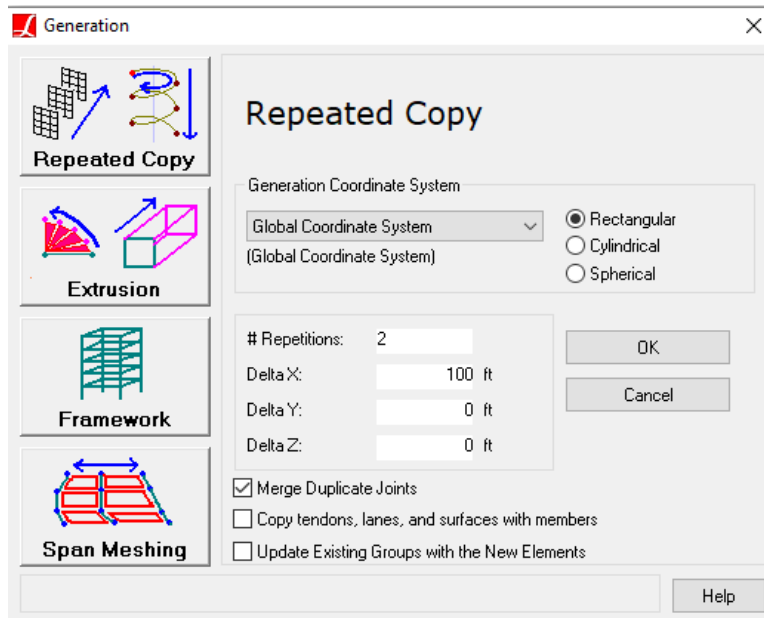

Generation Tool - Repeated Copy

The last step to complete the bridge geometry is adding restraints to the joints representing bearings.

- Using the selection tool or the keyboard shortcut **U**, unselect all elements.
- Select the bearing joints graphically, and using the Model Data Explorer assign appropriate restraints to the joints: The first, third, and fourth sets of bearings are restrained in Translation Y and Translation Z directions, and the second set of bearings are restrained in all three directions of translation.

Changes are applied to the model after clicking the checkmark button in the Model Data Explorer.

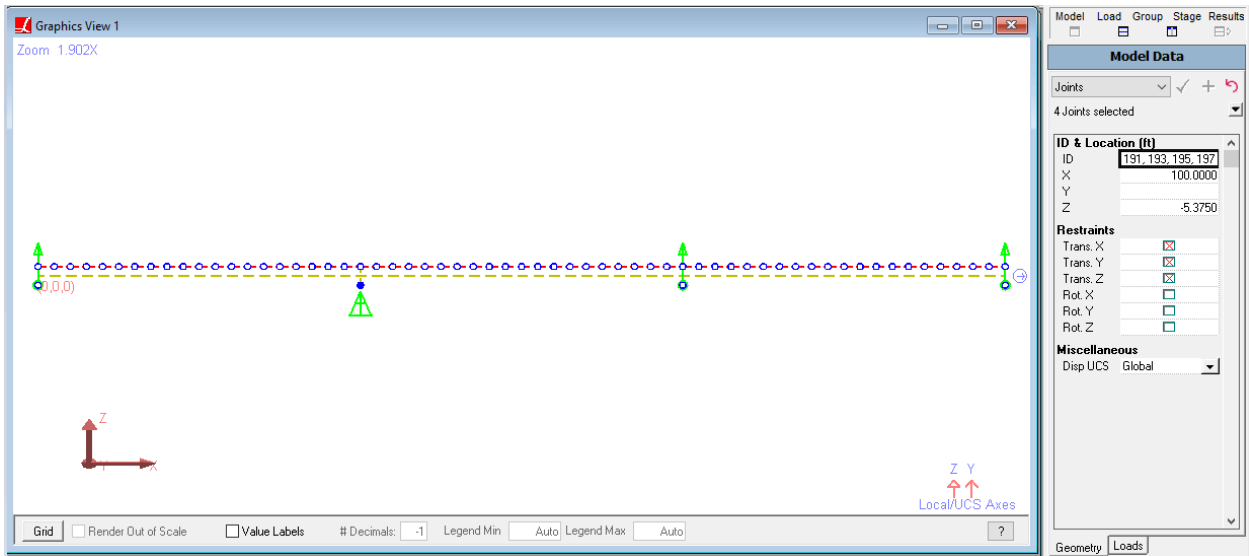

Bearings

For More Information, please refer to the following documentation.

- For model geometry reference, see Geometry in *LARSA 4D Reference Manual*.
- For more on using spreadsheets, see Using the Model Spreadsheets in *LARSA 4D User's Manual*.
- For help with drawing commands, see Drawing Geometry and Loads in *LARSA 4D User's Manual*.
- Generation Tools in *LARSA 4D User's Manual*.
- LARSA Section Composer in *LARSA Section Composer Manual*.



# Structure Groups

Structure groups provides quick access to particular parts of the structure.

Before moving forward to the loading, we will create Structure Groups in the project.

- ◆ Using the Selection Tools, unselect all elements and select all shells in the model.
- ◆ Go to **Selection** and **Select Joints of Selected Objects**.
- ◆ Click the **Group** button above the Model Data Explorer to activate the Structure Groups Explorer.
- ◆ Click the **Add Group** button in the Structure Groups Explorer to create a new structure group with the selected elements.
- ◆ Right-click the group and rename it as Deck.

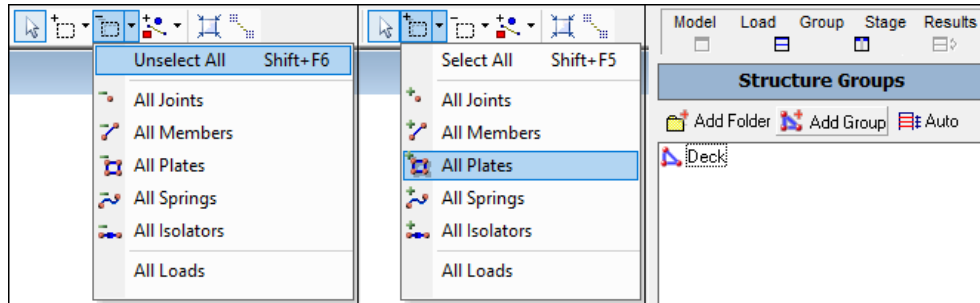

Structure Group for Deck

- ◆ Click the **Add Folder** button in the Structure Groups Explorer, and then click it and rename it to Girders.

Ensure the Girders folder is selected before creating the groups in the next step so that the groups are created with the girders folder.

- ◆ Using the Selection Tools, unselect all elements in the model.

The Select Special tool will be a fast way to select the girder members.

- ◆ Go to **Selection** → **Select Special**.
- ◆ Set the filters to select members whose material is A709-50.

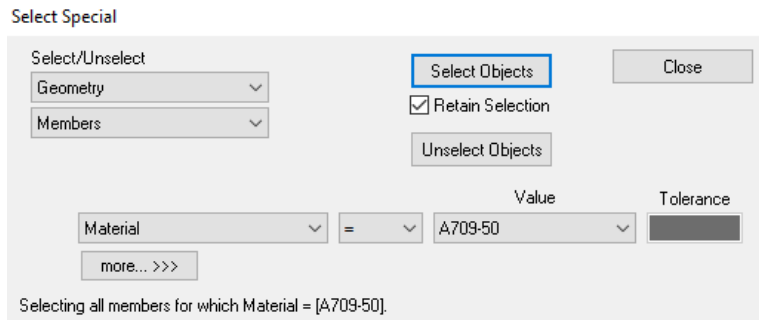

Select Special

☛ Go to **Selection** and **Select Joints of Selected Objects**.

☛ Click the Hide Unselected button in the toolbar to show only selected elements.

In addition to clicking on their icons, there are shortcut keys to quickly switch between the tools:

Unselect All → **U**

Select All → **S**

☛ Press **U** key on your keyboard to unselect the currently visible girder members.

☛ Use the Graphical Selection Tool to select individual girders and create structure groups named Girder 1, Girder 2, Girder 3 and Girder 4.

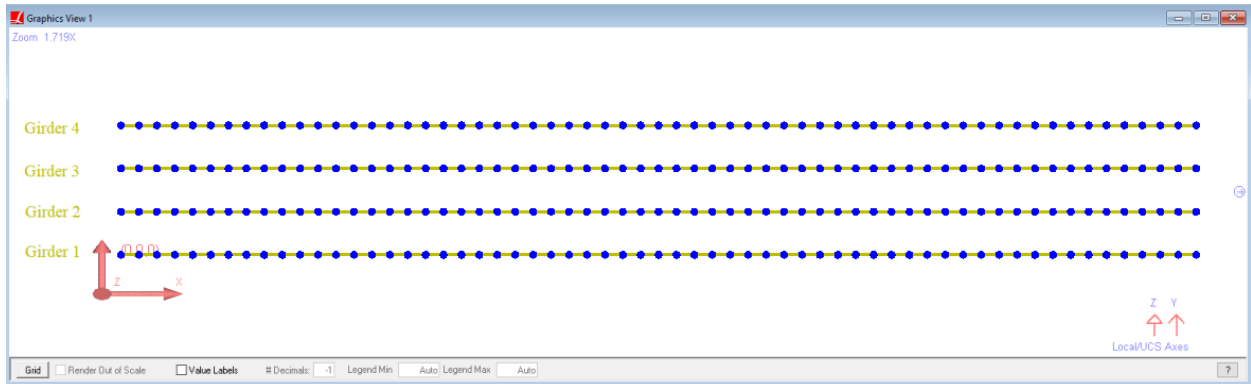

Structure Groups for Girders

We will also create a group for the rigid members together with the bearing joints.

☛ Click the empty area in the Structure Groups Explorer to inactivate the Girders folder so that the next group we add is not added within this folder.

☛ Click Hide Unselected button to show all elements.

☛ Press **U** key on your keyboard to unselect all elements in the model.

☛ Go to **Selection** → **Select Special**.

☛ Set the filters to select members whose material is Rigid Material.



- ☛ Click **Select Objects**.
- ☛ Go to **Selection** and **Select Joints of Selected Objects**.
- ☛ Click **Add Group** in the Structure Groups Explorer to create a structure group for the rigid members and name it Rigid Members.

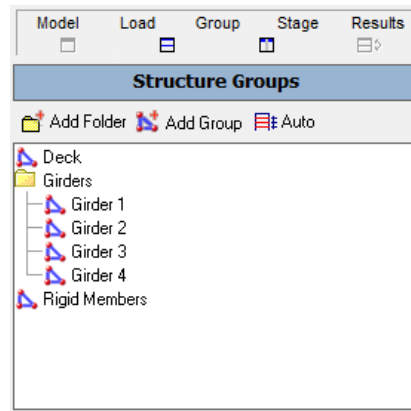

Structure Groups

---

For More Information, please refer to the following documentation.

- Structure Groups Explorer in *LARSA 4D User's Manual*.



# Self-Weight Dead Load

In this section we will create a static load case for self-weight only. The Load Cases Explorer is the primary way to create load cases.

- Click the **Load** button above the Model Data Explorer to activate the Load Cases Explorer.

The Load Cases Explorer will take the place of the Model Data Explorer.

- Add a new load case by clicking the **Add Load Case** button at the top of the explorer.
- Right-click the load case and choose **Properties**. Change its name to “Self Weight”. Then enter -1 in the Weight Factor Z field to indicate that gravity applies in the negative-z direction with a factor of one. (The **-Z** button enters this value for you.)
- Set the Load Class of this load case to Dead Load later to use in Staged Construction Analysis together with the loads from other load classes.
- Click **OK** to finish changing the properties of this load case.

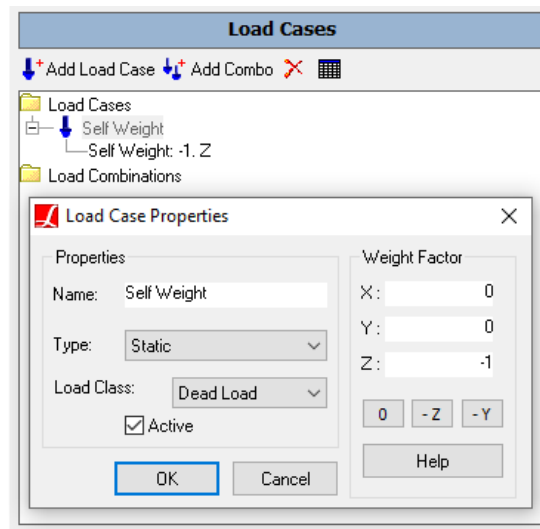

Self Weight Load Case

---

For More Information, please refer to the following documentation.

- Self Weight in *LARSA 4D Reference Manual*.



# Linear Static Analysis

At this point we will run a linear static analysis. The analysis will compute the effects of the self-weight load case created in the previous section.

- ☛ From the **Analysis** menu, choose **Linear Static / P-Delta Analysis**.
- ☛ There are no options for this analysis type. Click **Analyze**. You will be prompted to save the project. Do so.
- ☛ Once the analysis completes successfully, close the analysis window.

The Analysis Results Explorer will be automatically opened on the right side of the screen.

- ☛ Set the results units to the Imperial defaults (inches for displacement and kips for forces) in **Results** → **Units**.
- ☛ Open the Load Cases group and select the Self Weight result case from the Analysis Results Explorer.

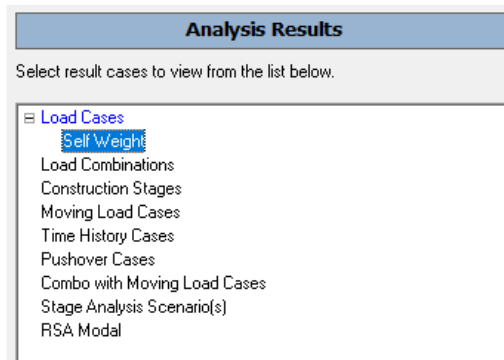

Select the Self Weight Result Case

There are several ways to examine analysis results in LARSA 4D, including graphics and spreadsheets. We will demonstrate graphical results first.

- ☛ Turn on **Deformed Model** graphical results either from the **Results** menu or the toolbar.

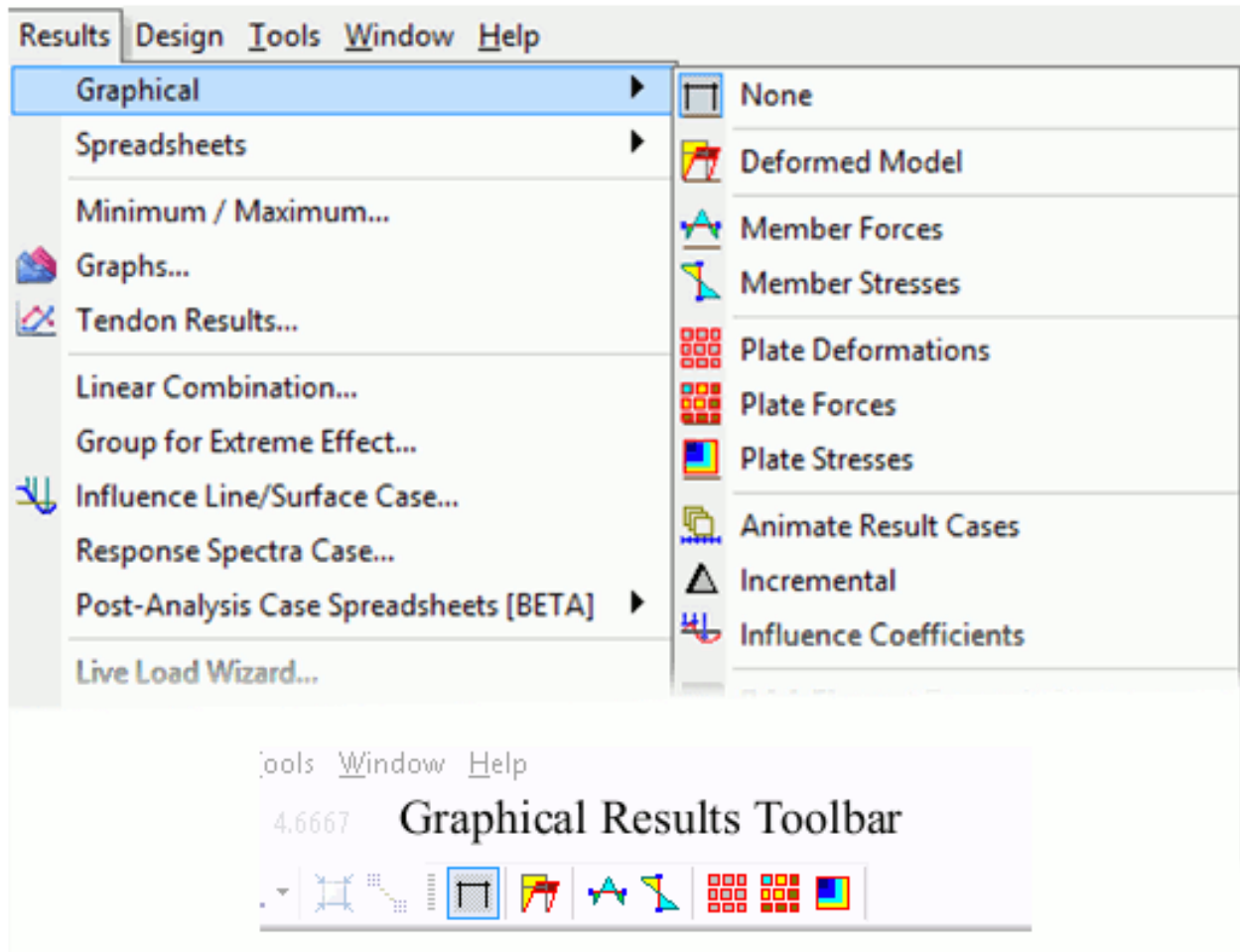

Graphical Results Menu and Toolbar

☛ Select all elements using **Selection** → **Select Objects** → **Select All**.

Results are only shown for selected elements.

☛ Drag up the scale factor slider until you can see deformation. The slider is at the bottom of the Analysis Results Explorer.



Graphical Results Scale Factor

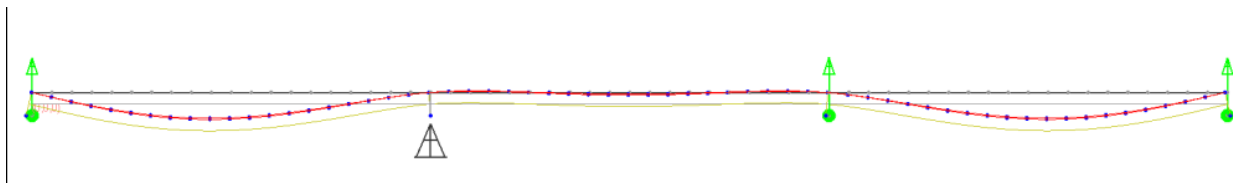

Deformed Model

Reaction labels can also be turned on from the floating Graphical Results Options tool window.

- ☛ Turn off graphical results by choosing **None** in the graphical results menu or toolbar.
- ☛ Open the stresses spreadsheet using **Results** → **Spreadsheets** → **Member** → **Stresses**.

The stresses spreadsheet shows stresses at pre-set locations on the perimeter of the cross-section called stress recovery points. Four stress recovery points have been pre-set for the I-shape at the four extreme corners.

Stresses are shown at segments within each member element. The number of segments to divide each member into is controlled in **Results** → **Results Display Settings**.

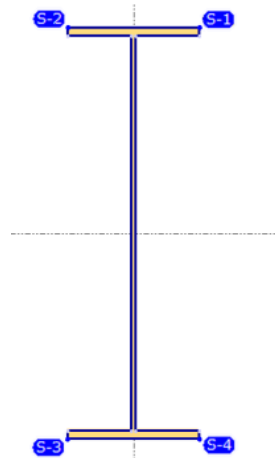

Member Stresses									
Min/Max for		None							<input type="checkbox"/> Incremental Results
	Member	Station	Result Case	(P/A) @ Centroid (kips/in <sup>2</sup> )	Normal Stress @ Point 1 (kips/in <sup>2</sup> )	Normal Stress @ Point 2 (kips/in <sup>2</sup> )	Normal Stress @ Point 3 (kips/in <sup>2</sup> )	Normal Stress @ Point 4 (kips/in <sup>2</sup> )	
1	1	0	Load Cases: Self Weight	0.3659	0.1428	1.8296	0.5890	-1.0979	
2	1	1	Load Cases: Self Weight	0.3659	0.0358	1.0316	0.6960	-0.2999	
3	1	2	Load Cases: Self Weight	0.3659	-0.0691	0.2357	0.8009	0.4960	
4	1	3	Load Cases: Self Weight	0.3659	-0.1718	-0.5580	0.9036	1.2898	
5	1	4	Load Cases: Self Weight	0.3659	-0.2724	-1.3496	1.0042	2.0814	
6	1	5	Load Cases: Self Weight	0.3659	-0.3709	-2.1391	1.1027	2.8709	
7	2	0	Load Cases: Self Weight	1.0505	0.1682	1.0463	1.9328	1.0548	
8	2	1	Load Cases: Self Weight	1.0505	-0.0349	0.4625	2.1360	1.6386	
9	2	2	Load Cases: Self Weight	1.0505	-0.2360	-0.1192	2.3370	2.2202	
10	2	3	Load Cases: Self Weight	1.0505	-0.4349	-0.6987	2.5359	2.7997	
11	2	4	Load Cases: Self Weight	1.0505	-0.6316	-1.2760	2.7326	3.3771	
12	2	5	Load Cases: Self Weight	1.0505	-0.8262	-1.8513	2.9272	3.9523	

Member Stresses

- ☛ Close the spreadsheet window before going on.

For More Information, please refer to the following documentation.

- Linear Static Analysis in *LARSA 4D Reference Manual*.
- Analysis Results Explorer in *LARSA 4D User's Manual*.
- Viewing Results Graphically in *LARSA 4D User's Manual*.
- Results Spreadsheets in *LARSA 4D User's Manual*.





# Influence Surface Live Load Analysis

Live load analysis with LARSA 4D can be performed in three ways, using the basic Moving Load Analysis, using Influence Lines, or using Influence Surfaces.

In the basic Moving Load Analysis, a vehicle load pattern is moved along a predefined path, called a lane, and at each position along the lane a linear elastic static analysis is performed. This type of analysis however, is too limited under modern bridge design codes which introduce more variables besides vehicle position, such as axle spacing, and when multiple vehicles are loaded, vehicle spacing.

The general influence method can be used to avoid this problem and to comply with bridge design codes, such as the AASHTO LRFD, which requires finding the worst case scenario out of more possibilities than can be analyzed individually.

With influence lines, a linear path along the model is created, usually along the centerline of the bridge deck, along which unit loads will be placed at regular intervals. Influence surfaces work similarly. Rather than creating a linear path over a series of members, with influence surfaces the user defines a surface on which a grid of unit loads are applied. Influence surfaces are used when the bridge deck is modeled with shells, rather than members. Note that the live load analysis with influence surfaces is a refined method of analysis that eliminates the use of girder distribution factors.

This tutorial will use the influence surface method to compute live load results for this model.

## Preparing the Influence Coefficients: The Surface

The first step for any live load analysis is to create a definition specifying where the loading will be applied. In moving load and influence analysis, the load pattern applied to the structure follows a defined path, starting at one end of the path and moving toward the other end. This path is defined by 3D control points along the centerline of the path. For influence surface analysis, we additionally specify a width.

If the design code calls for two or more traffic lanes on the bridge, an influence surface has many advantages over influence lines. With influence lines a separate lane definition must be created for each design lane. But with influence surfaces, a single surface can be created for the entire bridge deck. The influence surface solver will find the optimal locations of the design lanes within the surface. Additionally, the influence solver will apply multiple presence factors as needed, which in an influence line analysis is left to the user.

For any roadway surface geometry (straight, curved, skewed at ends), the influence surface definition can be created in Path Spreadsheets by defining a set of geometry control points.

- ◆ Open the Lanes/Surfaces panel of the Model Data Explorer.
- ◆ Click the plus sign to create a new surface.
- ◆ Right-click the new surface and choose **Rename**. Rename it as “Roadway”.
- ◆ Right-click the surface and choose **Edit Path & View**.

Two new windows will open. On top will be the path spreadsheet where geometry control points are entered.

## Surface Centerline

The centerline path of a surface is determined by geometry control points given as coordinates relative to shells in the model. The path is generally fit as straight line segments between the control points, and so for a straight bridge as few as two control points may be used (one at the start and one at the end).

We will establish a line through the shells that represents the centerline of the deck. We need a point at the start of the deck and a point at the other end.

The geometry control points on the path are at the origin of each shell's local coordinate system, which is at the shell's I-joint. So, we will take shell 61 at the start of the bridge and shell 400 at the end of the bridge, as a reference. (The shell IDs may be different in your model.)

You can Add, Insert or Delete Rows using the buttons in the toolbar.

- ☛ Add points for the shells 61 and 400 and set the Offset X of the second shell to 5 ft, which is the side length of the shell, to move that point from the origin of the shell to the edge of the shell at the end of the deck surface.

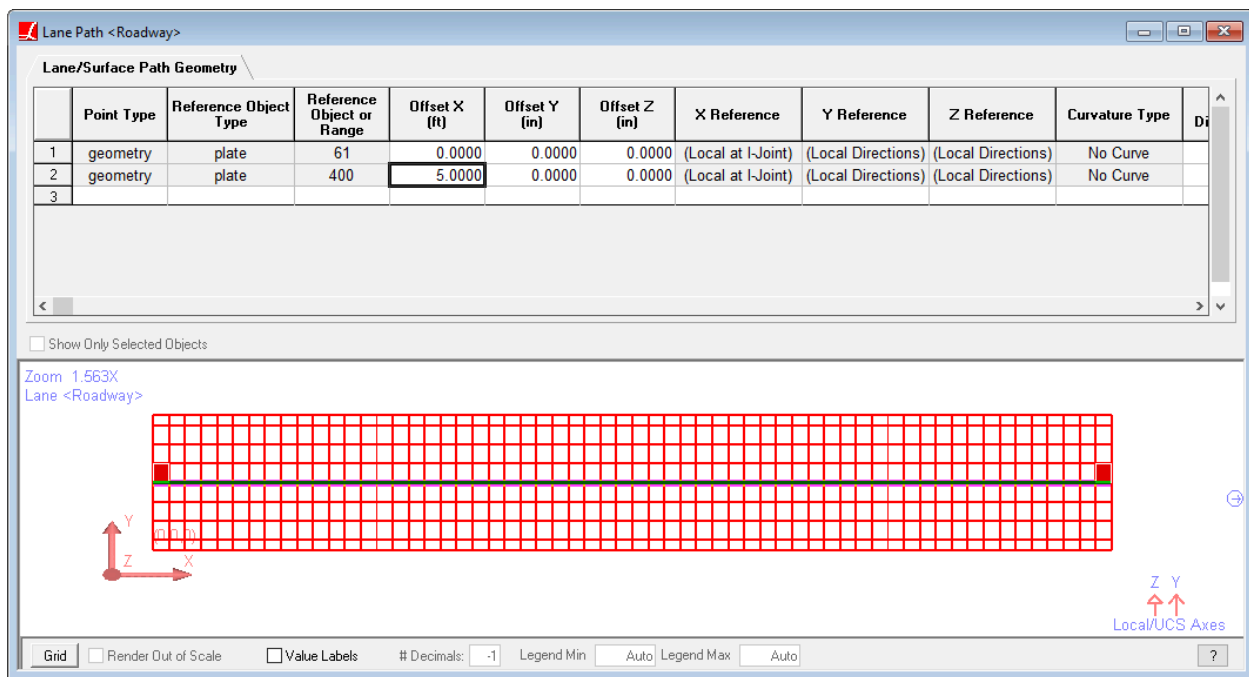

Roadway Path

## Span Break Markers

AASHTO LRFD and other design codes call for certain loading to be placed at most once per span to produce maximum force effects. You need to use "span break markers" to indicate the start and end of each span when this is necessary. A span break marker indicates that the previous geometry point in the spreadsheet marks the end of a span.

To add span break markers to this model, we will first need to add geometry points at the two supports. We will then add span break markers after those geometry points. The geometry points will be placed (at the origin of) the two shells immediately to the right of the two supports.

- ☛ Insert two rows in the appropriate place in the path spreadsheet to create geometry points on shells 221 and 381.

- ☛ Insert additional rows to make span break markers after the geometry points for shells 221 and 381. A row is turned into a span break marker by changing the Point Type to span mark.

Span break markers are indicated in the path graphics pane as small circles at the location of the previous geometry point.

	Point Type	Reference Object Type	Reference Object or Range	Offset X (ft)	Offset Y (in)	Offset Z (in)	X Reference	Y Reference	Z Reference	Curvature Type
1	geometry	plate	61	0.0000	0.0000	0.0000	(Local at I-Joint)	(Local Directions)	(Local Directions)	No Curve
2	geometry	plate	221	0.0000	0.0000	0.0000	(Local at I-Joint)	(Local Directions)	(Local Directions)	No Curve
3	span mark									
4	geometry	plate	381	0.0000	0.0000	0.0000	(Local at I-Joint)	(Local Directions)	(Local Directions)	No Curve
5	span mark									
6	geometry	plate	400	5.0000	0.0000	0.0000	(Local at I-Joint)	(Local Directions)	(Local Directions)	No Curve
7										

Span Break Markers

- ☛ Close the path spreadsheet window. The graphics window below it will also close.

### Surface Width

- ☛ Go to the lanes/surfaces spreadsheet in **Input Data** → **Geometry** → **Lanes/Surfaces**.
- ☛ Enter the width of the surface: 39 ft.

The surface is centered about the path we specified above.

It is possible to enter here a skew at the start and end of the surface if the start and end edges of the deck are not perpendicular to surface centerline, but it is almost never necessary. It is okay if the surface falls off the edge of the shells, so the customary way to deal with skewed edges is to simply extend the surface definition beyond the edge so that it encompasses the corner, as well as some dead space. If the skew fields are used, they must have the same value at start and at end for influence surface analysis.

- ☛ Close the Lanes/Surfaces spreadsheet.

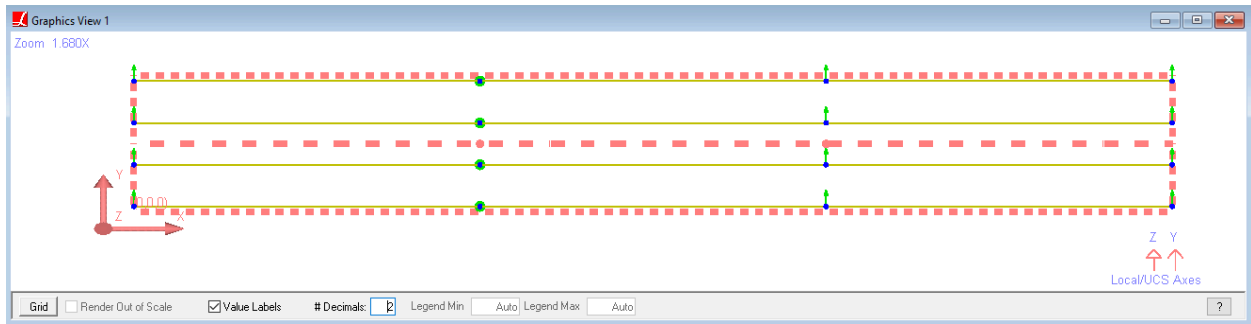

Roadway Surface

☛ If you cannot see the lane, open **Graphics** → **Show** and ensure **Lanes/Surfaces** is checked.

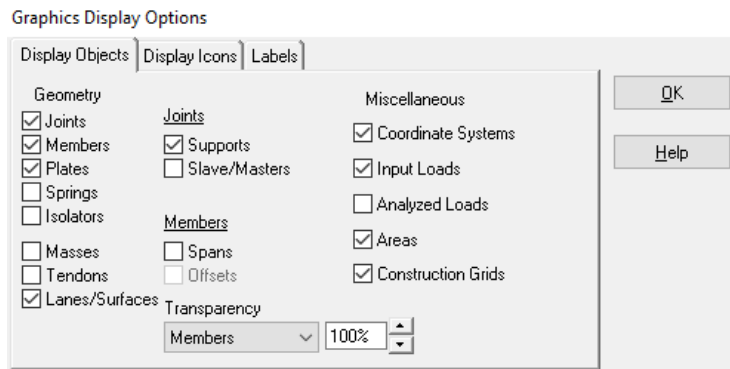

Graphics > Show

## Preparing the Influence Coefficients: The Load Case

The load case setup specifies additional options for how the lane is loaded, including the grid spacing of influence coefficients.

- ☛ Go to the Load Cases Explorer.
- ☛ In the Load Cases Explorer, add a new load case. Open the properties of the load case by a right-click.
- ☛ Name it as “Influence Coefficients”, set the type of load to Moving and the Load Class to Live Load.

The selection of a load class does not impact the analysis. It only affects the use of load class tracking tools such as extracted results.

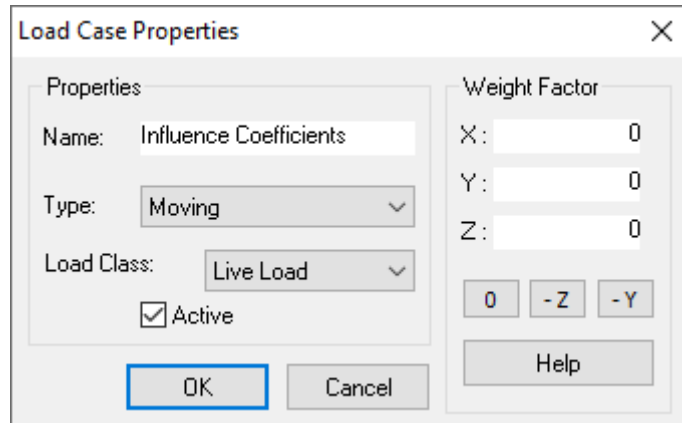

Load Case Properties

- ☛ Open the spreadsheets for the load case by double-clicking the load case. Then go to the **Moving Loads** tab, and then choose **Influence Loads** beneath the tabs.
- ☛ Add a new row to the spreadsheet indicating that LARSA 4D should load our surface with unit loads at a given grid spacing. Change the lane column to Roadway.

The choice of the forward increment and the transverse increment for the influence-surface analysis depend on the required accuracy of the results. However, smaller increment size may result in longer analysis time. The engineer needs to decide on the increment size of the unit load in order to balance the analysis time and the level of accuracy.

See the below screenshot showing the difference between strong axis bending moment (minimum and maximum) diagrams along a girder resulting from the influence-based live load analysis with two different forward increment inputs.

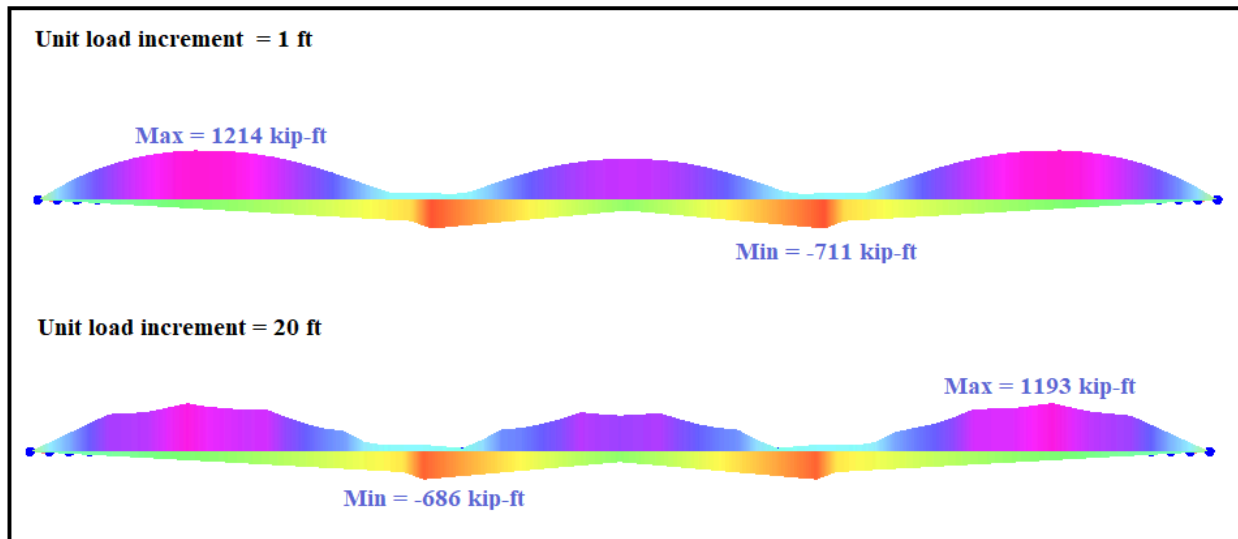

Effect of Increment Size

The unit load increment of 4 to 6 ft for the preliminary design and 1 to 3 ft for the final design is typically adequate.

- ☛ Set the Forward Increment to 5 ft and Transverse Increment to 3 ft.

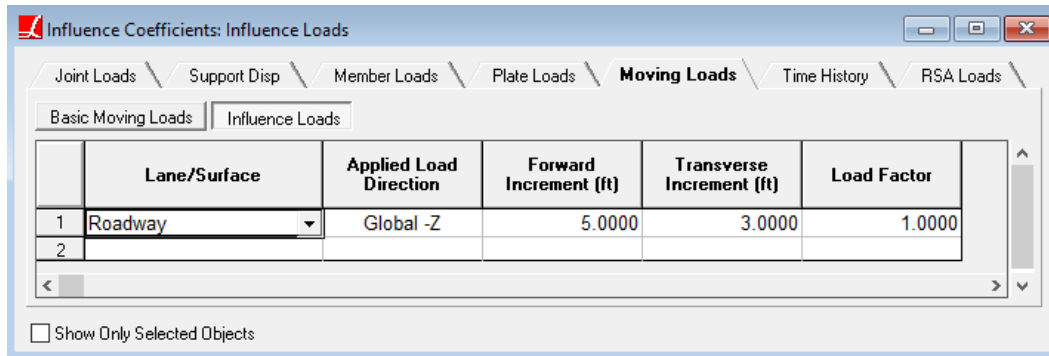

Influence Load

Since the bridge is 300 ft long and the roadway surface width is 39 ft, the 5 ft forward increment will generate 61 coefficients lengthwise. LARSA 4D will always adjust the transverse spacing so that the rows of coefficients are equally spaced from the roadway center. The 3 ft transverse increment will be adjusted to 3.25 ft having 13 rows, and this will yield 793 influence coefficients in total.

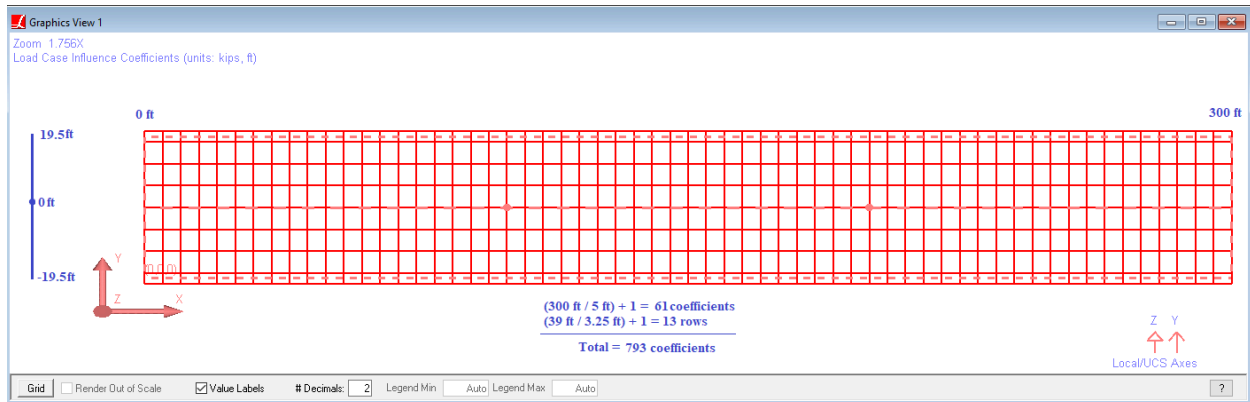

Influence Coefficients

Close the Influence Loads spreadsheet.

## Analysis

Run a Moving Load Analysis (Analysis → Moving Load Analysis (Static/Dynamic) → Analyze).

The result cases will be generated for the unit load applications throughout the deck surface.

After the analysis, you can see in the Analysis Results Explorer under the Moving Load Cases group there is a group of results called “Influence Surface - Influence Coefficients”.

Within this group are the linear static results for each influence unit load that applied to the structure on a grid throughout the lane surface. They are organized by offset, indicating transverse offset from the lane centerline, and station, indicating distance along the lane from the start.

## Connecting a Vehicle Database

We need to connect a moving load pattern database file to the project. This database will have the vehicle load patterns that you will apply to the structure later on.

- ☛ Go to **Input Data** → **Connect Databases**.
- ☛ Next click **Connect Standard Database**.
- ☛ Open the file “AASHTO Vehicle Patterns.dml”, which is a database of standard vehicle patterns that comes with LARSA 4D. It includes various vehicle patterns needed for AASHTO LRFD live load analysis.

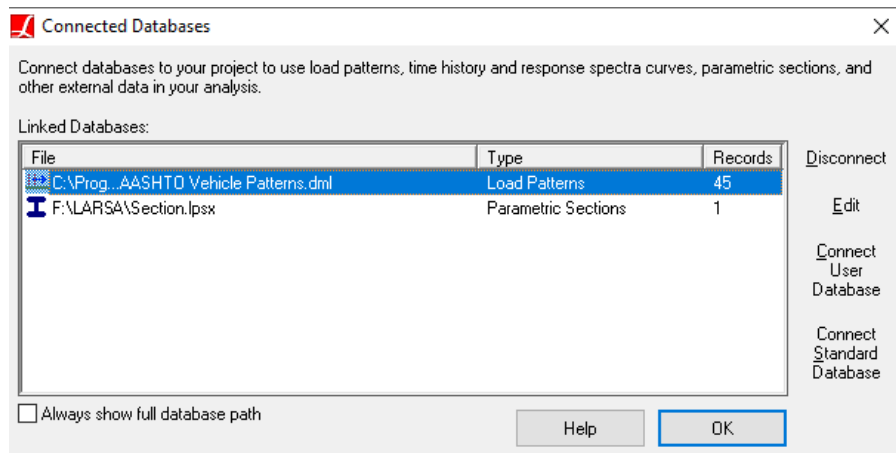

AASHTO LRFD Vehicle Patterns Database

- ☛ Click **OK** to close the Connected Databases window.
- ☛ Use **Input Data** → **Edit Databases** to see what the vehicle load patterns look like. Close the Database Editor when you are done.

## Vehicle Load Setup

In the AASHTO LRFD code, a lane is loaded with combinations of a Design Tandem or a Design Truck, and a Design Lane Load. LARSA 4D’s standard load pattern database consists of the following load patterns suitable for this code:

- HL-93 Design Truck in conformance with AASHTO LRFD 3.6.1.2.2. This truck has three axles of 8, 32, and 32 kips spaced (a minimum of) 14 ft apart. The spacing between the two 32 kip axles may vary between 14 ft and 30 ft to produce extreme force effects.
- HL-93 Design Tandem in conformance with AASHTO LRFD 3.6.1.2.3. The design tandem consists of a pair of 25 kip axles spaced 4 ft apart.

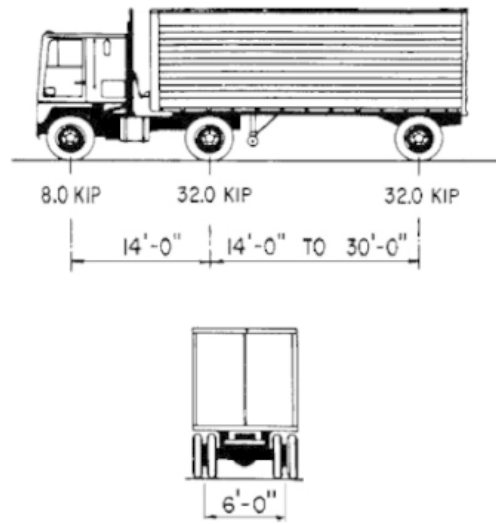

AASHTO LRFD HL-93 Design Truck

The uniform load (UDL) is specified separately from the vehicle type.

We now create an influence-based result case that has all of the additional configuration needed to get results for AASHTO LRFD.

- ☛ Go to **Results** → **Influence Line/Surface Case** and name the result case as “Influence Surface”.

### General Options

If the model had more than one surface, you would choose which one to load in the Influence Coefficients field.

- ☛ Set the Design Lane Width to 12 ft.
- ☛ Ensure that the Load for Extreme Force Effects option is turned on, which ensures that vehicles and wheels are only placed if they contribute to the extreme effect under consideration.

The extreme force effect option does not apply to lane loads, which are always applied as patch loading.

### Multiple Presence Factors

Multiple presence factors are applied to the results depending on the number of lanes actually loaded (which depends in turn on the multiple presence factors).

- ☛ Click the Edit button under Multiple Presence Factors.
- ☛ Enter the factors per AASHTO LRFD Table 3.6.1.1.2-1, and then click OK.



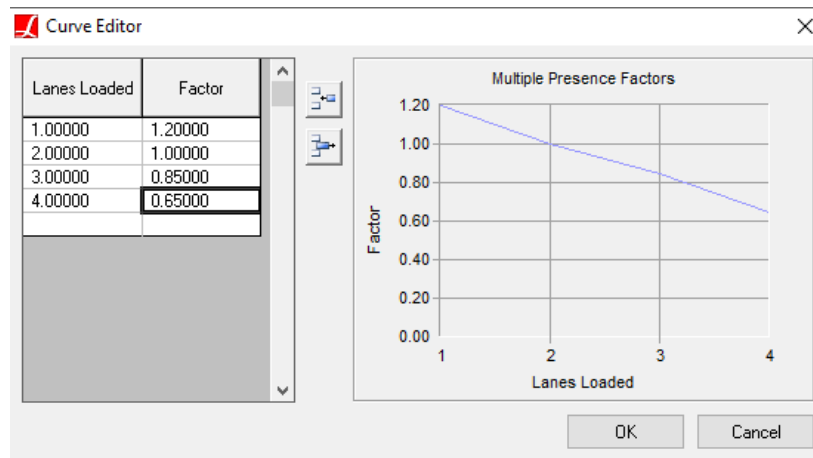

Multiple Presence Factors for Influence Surfaces

The final set of general options are shown below:

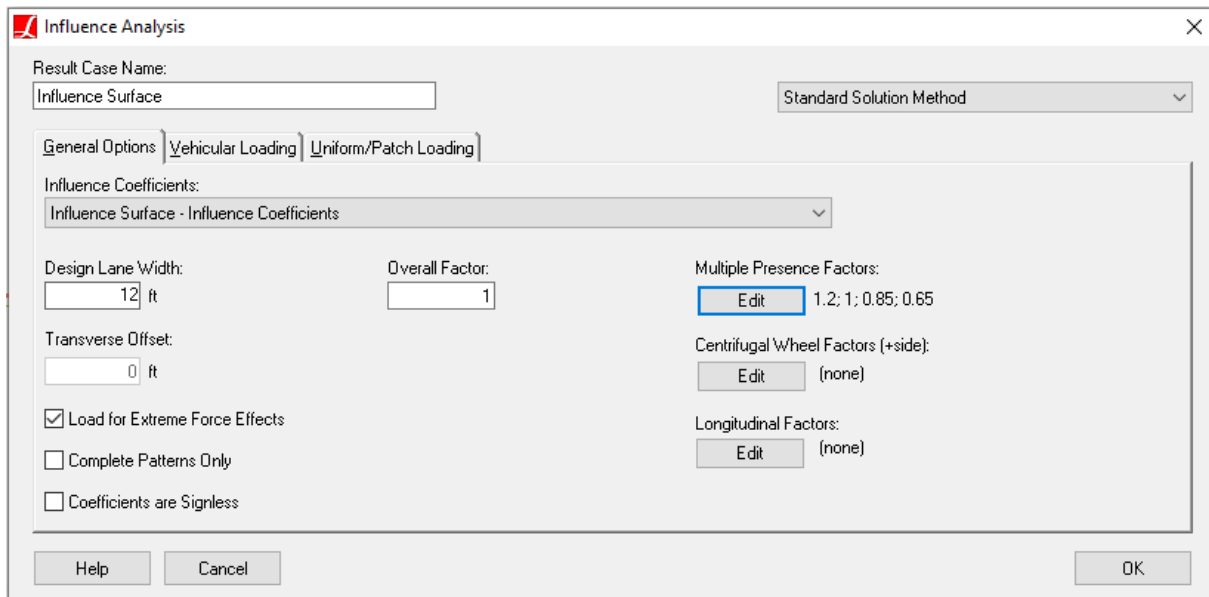

Influence Surface Result Case General Options

## Vehicular Loading

- ☛ Change to the **Vehicular Loading** tab.

In this tab you will configure the vehicle loading that will be applied to the structure. (Uniform patch loading is specified on the next tab.)

- ☛ Click **Add Lane Type**.
- ☛ On the right, where it reads **(Select Pattern)**, click it and choose HL-93/HS20-44 2D Design Truck (make sure you click the one with 2D in its name).

Another advantage of the influence surface method over the influence line method is the ability to apply "two-dimensional" load patterns. In these load patterns, each wheel is treated as a separate point load with an appropriate transverse offset. "2D" load patterns are named with "2D" in their name in the LARSA standard database. It is always recommended to use "2D" vehicle load patterns when using influence surfaces. The 2D load patterns model the width of vehicles, which is used to determine the area on the design lane applicable for vehicle loading and is used for the option for excluding the uniform lane load under vehicles.

We will come back to the other HL-93 live loading conditions a little bit later on in this tutorial. For now, we will save these settings and look at the results so that you can see what these settings mean so far.

- ☛ Close Influence Surface Case properties window by clicking the **OK** button.

## Live Load Results

### Graphical Results

The new influence-based result case can provide results in the same manner as any other load case: through the spreadsheet, graphically, or using any of the tools on the Results menu. The results from an influence-based result case are the positive and negative worst-case scenarios for the application of the live load as configured in the result case.

We will start by looking at reactions.

- ☛ In the Analysis Results Explorer, click the plus sign next to "Influence-Based" and click the new result case "Influence Surface" to activate it .
- ☛ Back in the graphics window, put the display in a 3D perspective so the deck surface is clearly visible.
- ☛ Make sure supports are visible in **Graphics** → **Show**.
- ☛ Turn on deformed model graphical results. No results will display because deformed model cannot show enveloped results, and envelopes are required when accessing influence-based results.
- ☛ In the floating Graphical Results Options tool window, click the fourth icon from the left which turns on Influence Coefficients View.
- ☛ Also in the floating results options window, change Translation Tx to Reaction Fz.

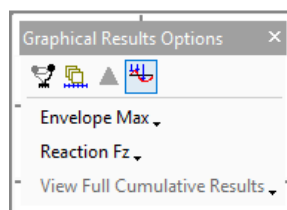

Turning On Influence Coefficient Graphical View

- ☛ Activate the Pointer Tool from the toolbar.

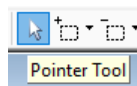

Pointer Tool

The pointer tool is used to pick items in the graphics window.

With the Pointer Tool, click the outer support at Pier 2 location.

The graphics window will show the influence coefficients as a graph over the surface of the deck. The coefficients represent reaction forces at the support we chose caused by point loads at different locations on the surface.

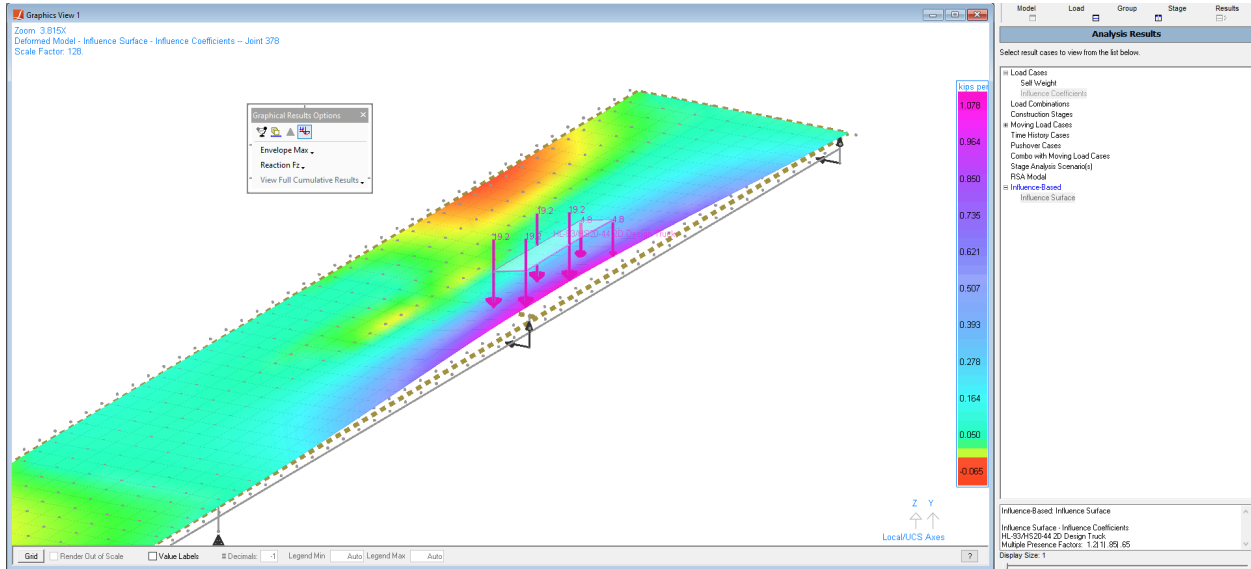

HL-93 Design Truck

The large purple arrows above the deck represent the critical vehicle position. Loading one lane with HL-93 Design truck near the chosen support produces the maximum vertical reaction at this support.

Note that in case of one lane loaded, the multiple presence factor of 1.2 is applied.

### Spreadsheets

Accessing results in the spreadsheets works as usual, except you must choose an envelope column. In this case, you would choose the Fz column to envelope on in the Joint Reactions spreadsheet. The rows of the spreadsheet then show the min and max Fz values for the supports, plus corresponding forces in the other directions.

In addition to graphical results, you may check where LARSA 4D decided to place the truck and lane load to produce the extreme effect by looking at the Result Case column on the spreadsheet. It indicates the station number (in coordinate units) from the start of the surface and transverse offset from the surface centerline (negative is on the right side, following the right hand rule) at which each vehicle is placed (referring to the front of the vehicle). “mp” indicates the multiple presence factor applied.

Joint	Result Case	Force X (kips)	Force Y (kips)	Force Z (kips)	Moment X (kips-ft)	Moment Y (kips-ft)	Moment Z (kips-ft)
1	190	Influence Surface: s159.5/t4.227/d1.; s159.5/t16.5/d1.	0.0000	-3.0319	-4.7623	0.0000	0.0000
2	190	Influence Surface: s28./t-16.5/d1. * 1.2 (mp)	0.0000	-1.9059	61.2311	0.0000	0.0000
3	191	Influence Surface: s260.5/t-16.5/d1.; s263./t-4.454/d1.; s158.3/t16./d0. * 0.850 (mp)	-65.0490	-0.7556	-11.3872	0.0000	0.0000
4	191	Influence Surface: s109.7/t-16.5/d0. * 1.2 (mp)	2.7134	-0.8655	70.6927	0.0000	0.0000

Spreadsheets

## Finishing Vehicle Loading and Adding Uniform Lane Loading

### Finishing Vehicle Loading

We now modify the “Influence Surface” result case so that it has all of the additional configuration needed to get results for AASHTO LRFD.

Per AASHTO LRFD Article 3.6.1.3, the extreme force effect shall be taken as the larger of the following:

- The effect of the design tandem combined with the effect of the design lane load, or
- The effect of one design truck with the variable axle spacing specified in Article 3.6.1.2.2, combined with the effect of the design lane load, and
- For negative moment between points of contraflexure under a uniform load on all spans, and reaction at interior piers only, 90 percent of the effect of two design trucks spaced a minimum of 50.0 ft between the lead axle of one truck and the rear axle of the other truck, combined with 90 percent of the effect of the design lane load. The two design trucks shall be placed in adjacent spans to produce maximum force effects.

We will also apply a dynamic load allowance of 33% to increase the static effects of the design truck or tandem for vehicular vertical load, per AASHTO LRFD Article 3.6.2.1.

☛ In the Analysis Results Explorer, right-click the Influence Surface case and choose **Properties**.

☛ Go back to **Vehicular Loading** tab one more time.

☛ Click the existing vehicle loading and set the factor (just below the vehicle type selection) to 1.33.

☛ Click **Add Lane Type**. Set the vehicle for this lane to HL-93 Design Tandem 2D and apply the 1.33 factor.

A Lane Type refers to the way a design lane may be loaded. The influence surface solver will choose the lane type for each loaded lane that produces the most extreme effects. The next lane type will be for the two trucks condition.

☛ Click **Add Lane Type** a third time. Set the (first) vehicle for this lane to HL-93/HS20-44 2D Design Truck and apply a 1.197 factor (which is 0.9 times 1.33).

☛ Click **Add Vehicle**. A second HL-93/HS20-44 2D Design Truck with the same factor is added into this lane type.

☛ Set the UDL Factor to 0.9. This applies to the current lane type. (We have not yet set the UDL magnitude.)

☛ Set the minimum back-to-front spacing to 50 ft.

☛ Turn on the option One Load Pattern Per Span.

Per AASHTO LRFD Article 3.6.1.3, the design truck or tandem shall be positioned transversely such that the center of any wheel load is not closer than 2 ft from the edge of the design lane.

☛ Set the design lane vehicle margin to 2 ft.

The LARSA 4D lane positioning algorithm also determines the transverse placement of the vehicle to produce extreme effects.

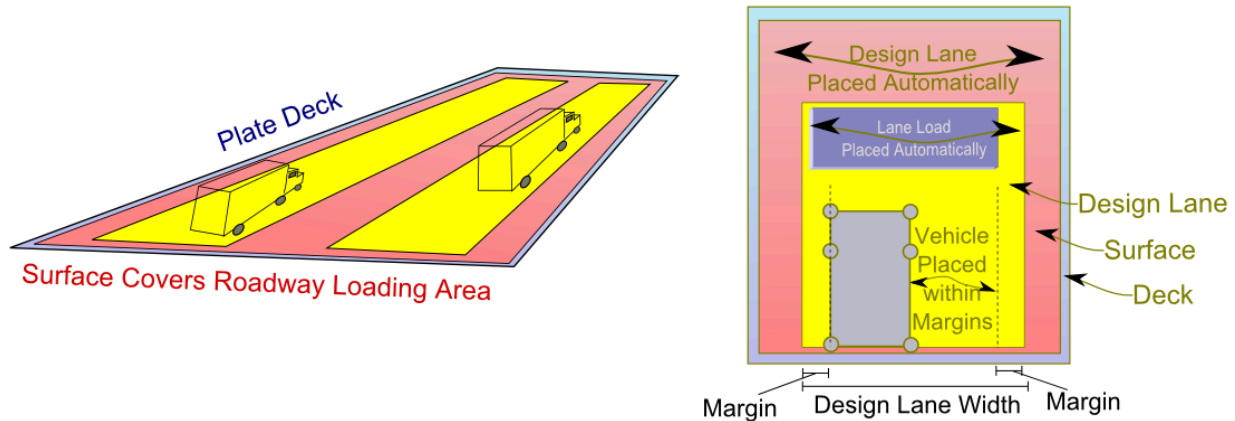

Transverse placement of the vehicle

☛ Verify that your screen looks like the following figure:

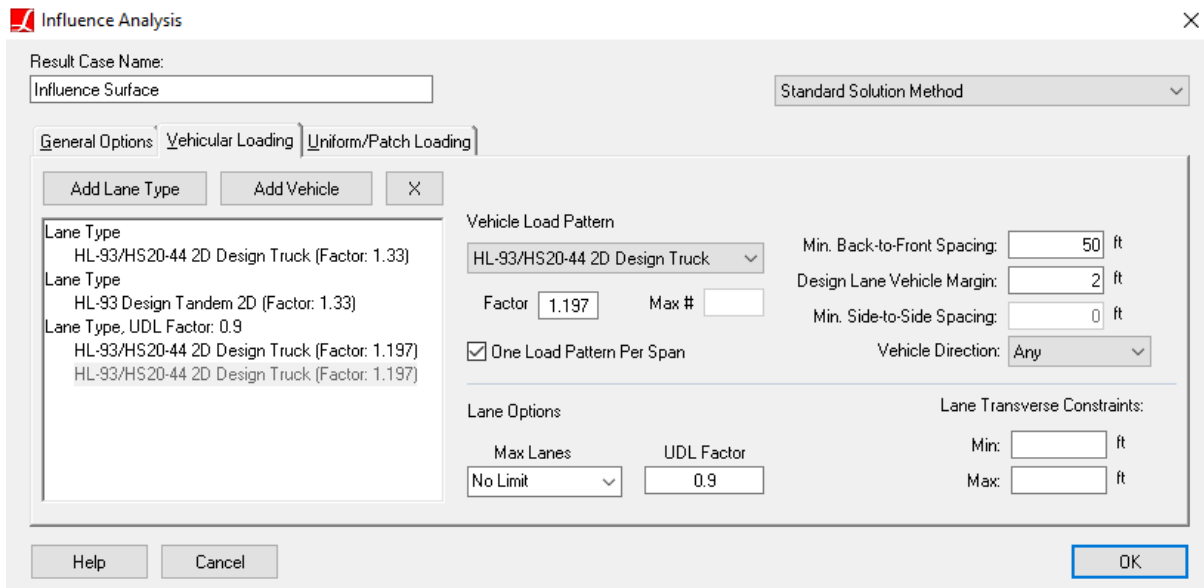

Influence Surface Vehicle Configuration

### UDL Setup

Per AASHTO LRFD Article 3.6.1.2.4, the design lane load shall consist of a load of 0.64 klf uniformly distributed in the longitudinal direction. Transversely, the design lane load shall be assumed to be uniformly distributed over a 10.0 ft width.

- ☛ Change to the **Uniform/Patch Loading** tab.
- ☛ Enter a UDL magnitude of 0.64 kip/ft.
- ☛ Set the UDL Width per Design Lane to 10 ft.

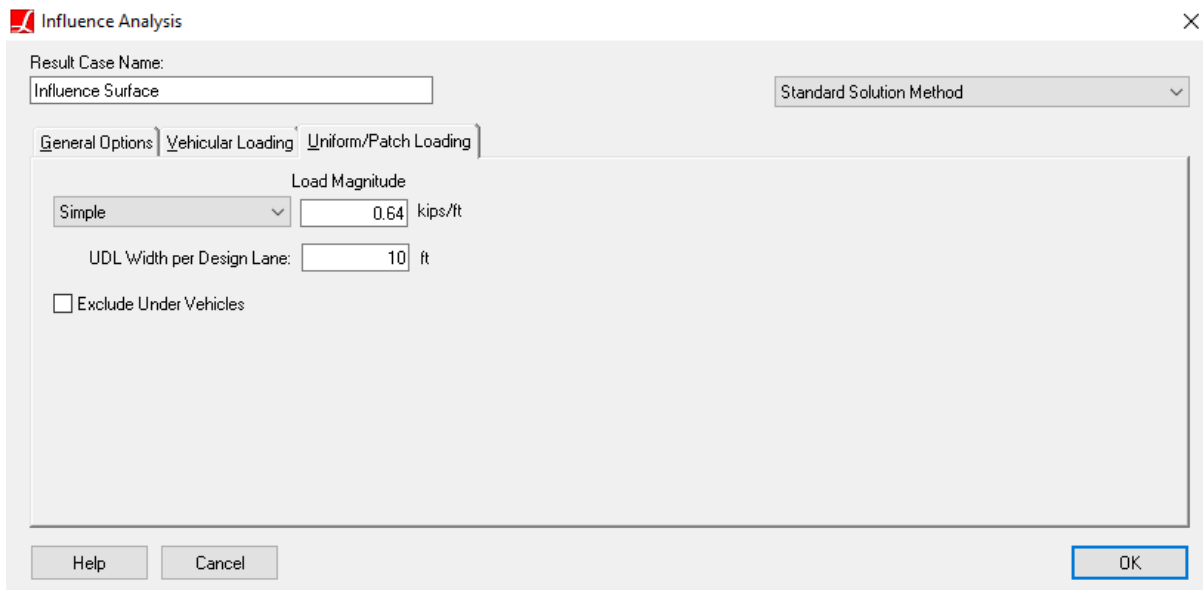

Influence Surface Patch Loading Configuration

- ☛ Click **OK**.

## AASHTO LRFD Results

Now, we will look for the critical vehicle position to maximize the major axis bending moment in a member.

- ☛ Turn on member force graphical results using the toolbar.
- ☛ In the floating Graphical Results Options tool window, choose Moment Mz and Envelope Max.
- ☛ With the pointer tool, choose member 153 on Girder 1 (which is midspan, the fifth member from Pier 1). When asked, enter station 0.

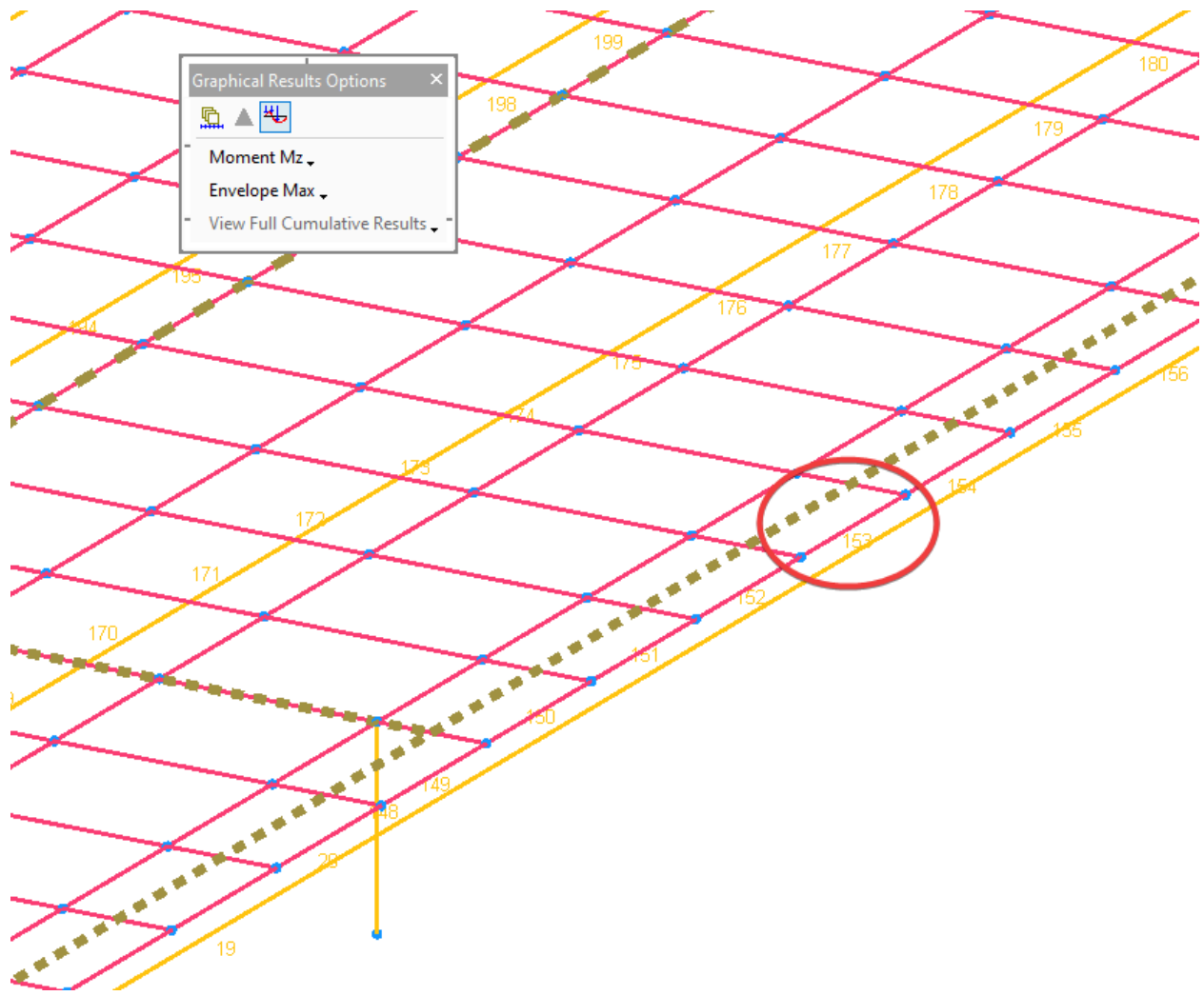

Girder 153

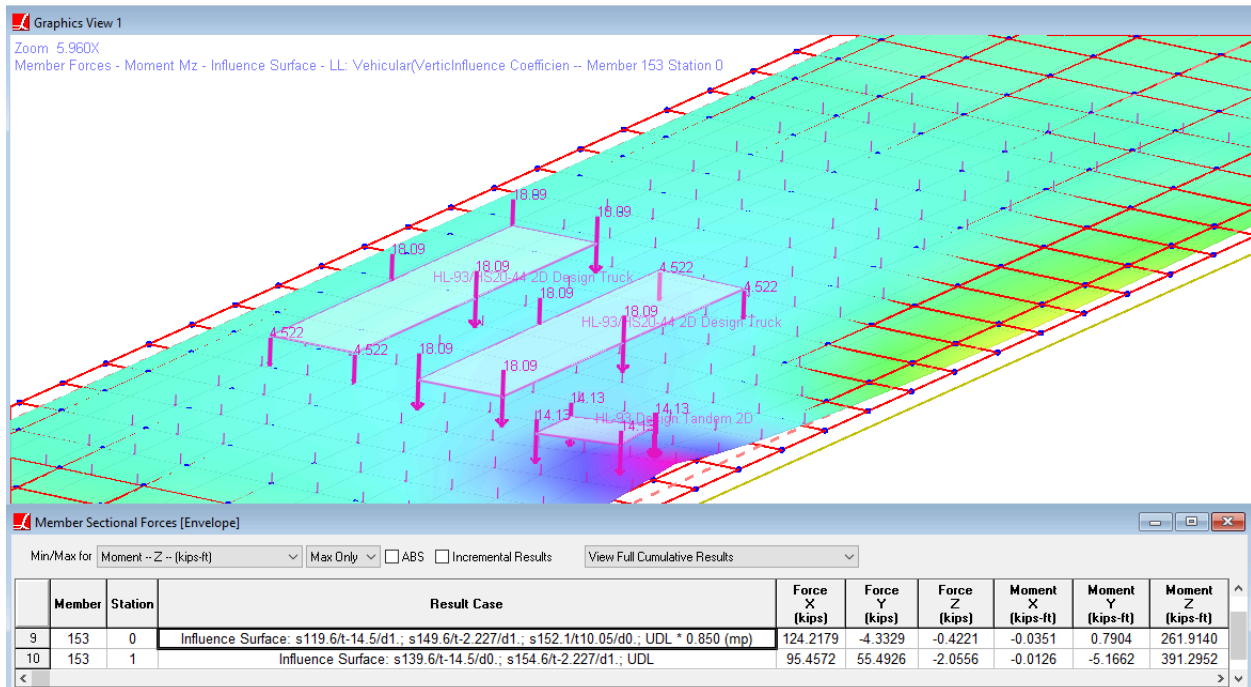

Positive Flexure

A combination of the single HL-93 Design Truck and the HL-93 Design Tandem governs for positive flexure.

- ☛ In the floating Graphical Results Options tool window, change Envelope Max. to Envelope Min.

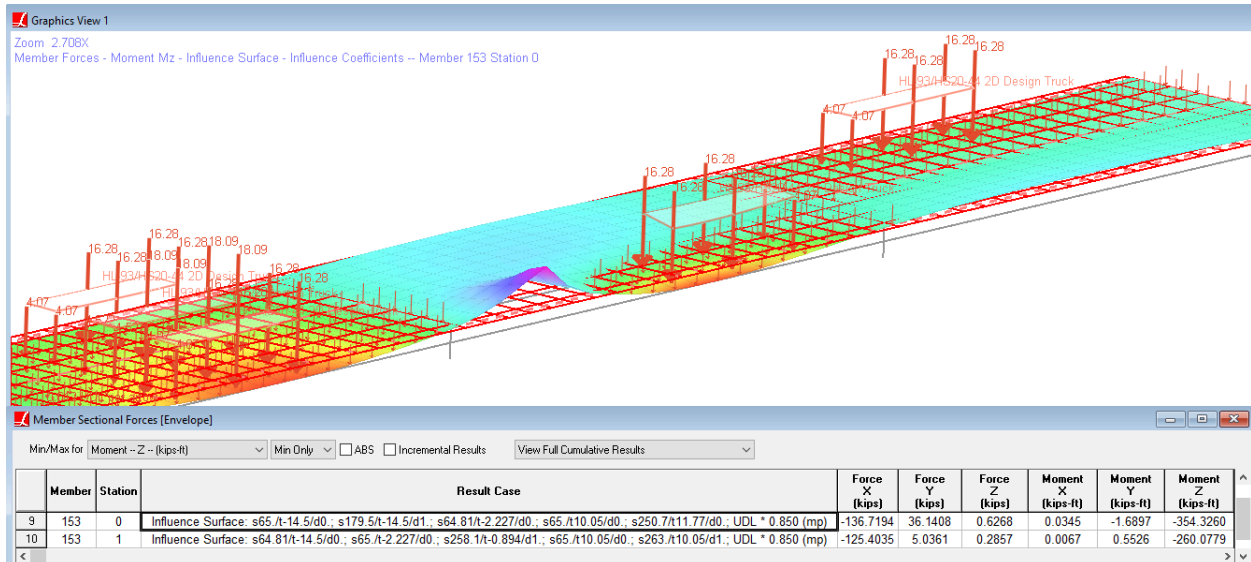

Negative Flexure

A combination of the single HL-93 Design Truck and two HL-93 Design Trucks governs for negative flexure.

- ☛ Turn off graphical results before going on.



## Girder Distribution Factors (GDF)

In this section of the manual, we will illustrate how the live load analysis with influence surfaces eliminates the use of girder distribution factors (GDF).

*The midspan of Girder 2 is taken as the reference to extract the results from the model.*

First, we will calculate the factor for the distribution of live loads per lane for moment in interior beams, per AASHTO LRFD Bridge Design Specifications. Then, we will approximately calculate the moment in Girder 2 using the girder distribution factor and compare it with the current results.

### **One Design Lane Loaded**

$$GDF = 0.06 + \left(\frac{S}{14}\right)^{0.4} \left(\frac{S}{L}\right)^{0.3} \left(\frac{K_g}{12Lt_s^3}\right)^{0.1}$$

$$S = \text{girder spacing } (3.5 \text{ ft} \leq S \leq 16 \text{ ft}) = 12 \text{ ft}$$

$$L = \text{span length } (20 \text{ ft} \leq L \leq 240 \text{ ft}) = 100 \text{ ft}$$

$$t_s = \text{structural concrete deck thickness } (4.5 \text{ in} \leq t_s \leq 12 \text{ in}) = 9 \text{ in}$$

### **Two or More Design Lanes Loaded**

$$GDF = 0.075 + \left(\frac{S}{9.5}\right)^{0.6} \left(\frac{S}{L}\right)^{0.2} \left(\frac{K_g}{12Lt_s^3}\right)^{0.1}$$

$$K_g = n(I + Ae_g^2)$$

$$n = \text{modular ratio} = \frac{E_s}{E_c} = \frac{29000 \text{ kip/in}^2}{3605 \text{ kip/in}^2} = 8.04$$

$$I = \text{moment of inertia of the steel girder} = 55476 \text{ in}^4$$

$$A = \text{cross sectional area of the steel girder} = 81.6 \text{ in}^2$$

$$e_g = \text{distance from centroid of the steel girder to the midpoint of the concrete deck} = \frac{9 \text{ in}}{2} + 31.5 \text{ in} = 36 \text{ in}$$

$$K_g = 8.04(55476 + 81.6 * 36^2) = 1.297 * 10^6 \text{ in}^4$$

$$\text{One Design Lane Loaded} \quad GDF = 0.06 + \left(\frac{12}{14}\right)^{0.6} \left(\frac{12}{100}\right)^{0.2} \left(\frac{1.297 * 10^6}{12 * 100 * 9^3}\right)^{0.1} = 0.578 \text{ lanes}$$

$$\text{Two or More Design Lanes Loaded} \quad GDF = 0.075 + \left(\frac{12}{9.5}\right)^{0.6} \left(\frac{12}{100}\right)^{0.2} \left(\frac{1.297 * 10^6}{12 * 100 * 9^3}\right)^{0.1} = 0.858 \text{ lanes}$$

### Calculation of GDF for Moment in Interior Beams

Per AASHTO LRFD Article 3.6.1.1.2, multiple presence factors shall not be used with the approximate load assignment methods other than statical moment or lever arm methods because these factors are already incorporated in the distribution factors.

- ☛ In the Analysis Results Explorer, right-click the influence surface case and choose **Duplicate**.
- ☛ Right-click the duplicated result case and choose **Properties**.
- ☛ Click the Edit button under Multiple Presence Factors.
- ☛ Remove factors using the **Remove Point button** then click **OK**.

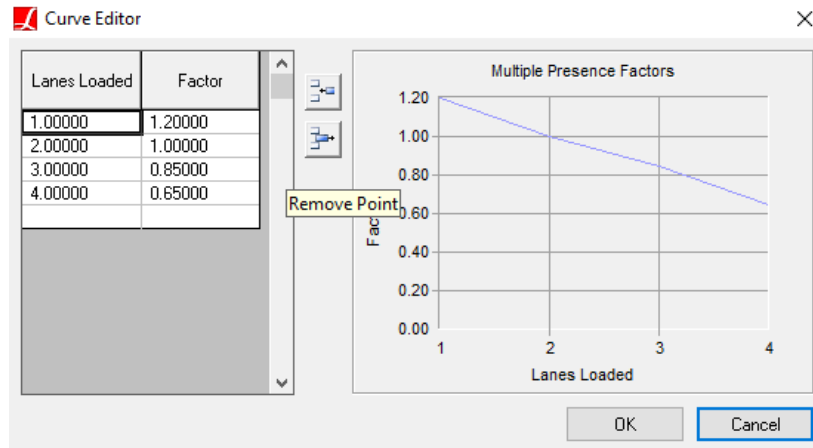

Remove Multiple Presence Factors

- ☛ Rename the result case as “Influence Surface\_noMPF” and close the properties window.

We will extract the maximum strong axis bending moment in the **bridge cross section** (similar to a line girder model) at 50 ft by using the Compound Element Forces tool which reports the combined forces and moments of a group of elements about their combined centroid. The tool will be explained in detail at the end of the Staged Construction Analysis section.

- ☛ Make sure that all elements are selected in the model.
- ☛ Click the new result case “Influence Surface\_noMPF” to activate it in the Analysis Results Explorer.
- ☛ Open the Compound Element Forces tool through the Results menu (Results → Compound Element Forces).
- ☛ Change the option of slicing the structure at **certain intervals** to **a particular position**.
- ☛ Slice the structure at 50 ft from the start of Global Coordinate System and choose to envelope on Moment Y for the maximum.
- ☛ Click **Show Compound Element Forces**.

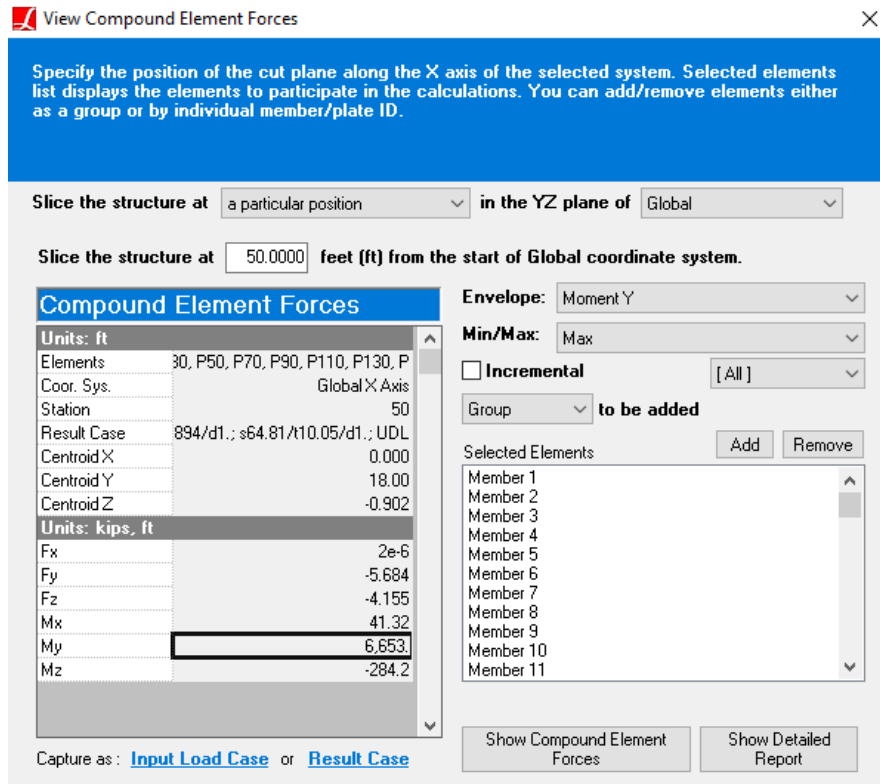

Compound Element Forces - Slice at a Particular Position

The maximum strong axis bending moment in the bridge cross section at station 50 ft is found as 6653 kip-ft.

In order to maximize the strong axis bending moment in the middle of the first span, the critical vehicle configuration would be all three lanes are loaded by single HL-93 Design Truck:

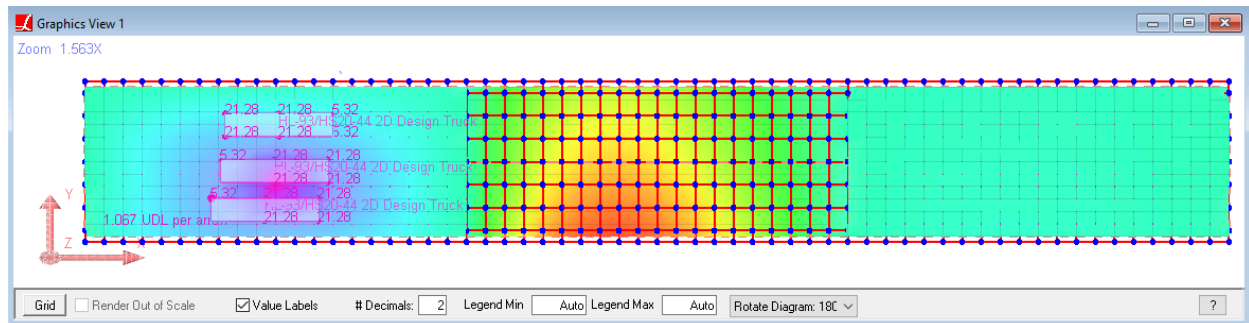

Three Lanes Loaded by Single HL-93 Design Truck

If you click **Input Load Case** command in the bottom left of the View Compound Element Forces window, a new load case will appear in the Load Cases Explorer, which contains the analyzed shell loads for vehicle axles and lane load of the corresponding vehicle configuration. You can review the load case to see that all three lanes are loaded.

On a side note, **Result Case** command in this window is used to create a new result case from the corresponding critical vehicle position. It allows you to review all results at that instant.

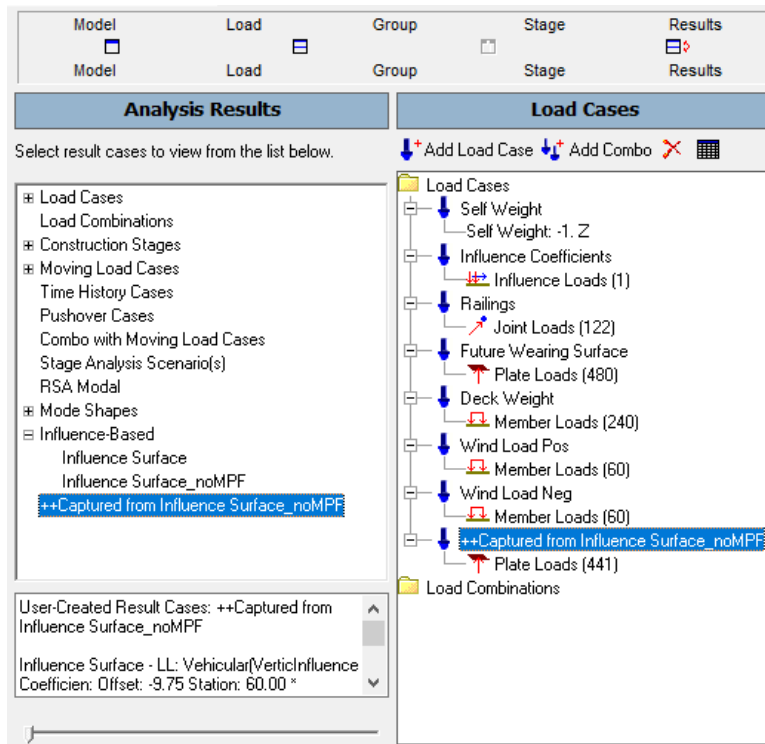

Capture From Influence-Based Result Case

- ☛ Close the View Compound Element Forces window by clicking on its X close button.

Now, we can approximately calculate the moment in the composite section of Girder 2 at station 50 ft:

$$M_{\text{girder2}} = 0.858 \text{ lanes} \times (6653 \text{ kip-ft} / 3 \text{ lanes}) = 1902.758 \text{ kip-ft}$$

The influence-surface based live load analysis eliminates the use of live load distribution factors and this moment can be determined directly and more accurately from the “Influence Surface” result case:

- ☛ Using the toolbar, change the graphics view to the Top Plane.
- ☛ Using the selection tools in the menu, unselect all elements.
- ☛ Click-and-drag a window from right to left around the second girder. Members of Girder 2 and deck shells on each side of the girder will be selected.

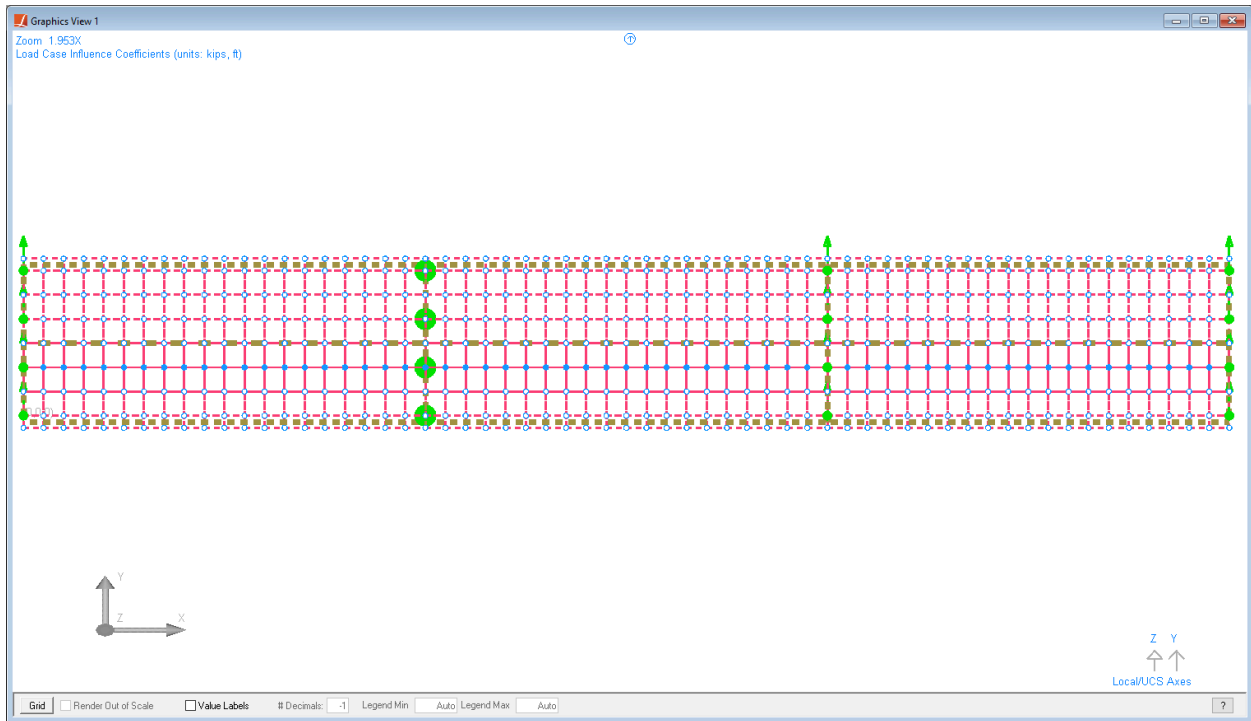

Girder 2 Selected

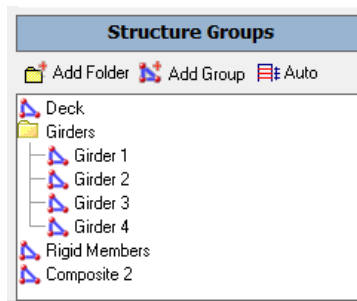

Composite Structure Group

- ☛ In the Structure Groups Explorer, add a new structure group and rename it as “Composite 2”. We will use this group in the next section of the manual.
- ☛ Click the result case “Influence Surface” to activate it in the Analysis Results Explorer.
- ☛ Following the similar steps, extract the strong axis bending moment in the composite section of Girder 2 at station 50 ft:

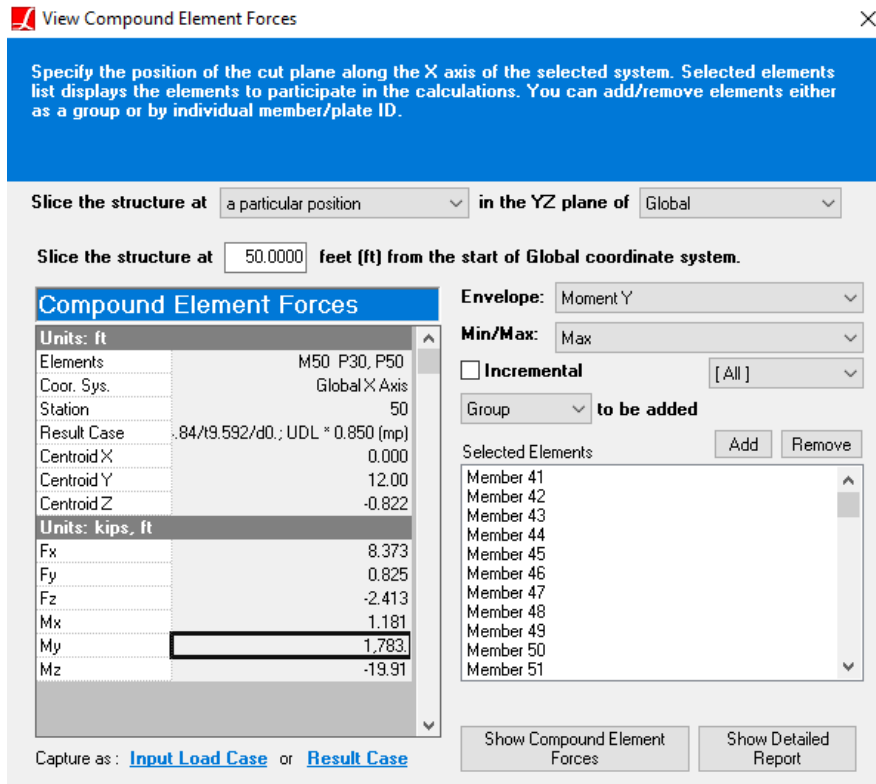

Moment Without Using GDF

The strong axis bending moment is found to be 1783 kip-ft from the influence-surface based result case, without using girder distribution factors.

For More Information, please refer to the following documentation.

- Lanes in *LARSA 4D Reference Manual*.
- Influence Line & Surface Analysis in *LARSA 4D Reference Manual*.
- Influence Coefficients Graphical View in *LARSA 4D User's Manual*.

# Staged Construction Analysis

Staged Construction Analysis is a “4D” analysis. What is meant is that the analysis models changes to the structure over time. In this section we will create a basic setup for staged construction using construction and loading activities.

Before setting up the construction stages, we will define additional loads on the bridge.

## Define Loads On Deck

In addition to self weight and live load, railing load at the edges of deck and future wearing surface load on the roadway surface will be defined.

For these loadings, we can use a simple tool called Define Loads on Deck.

- ☛ Go to **Draw** → **Define Loads On Deck**
- ☛ Since we already have a roadway surface and live load case defined in the model, uncheck the **Create Lane On Deck** checkbox.
- ☛ Check the **Barriers, Parapets and Bridge Rails** checkbox and enter 0.5 kips/ft as its magnitude.
- ☛ Check the **Future Wearing Surface** checkbox and enter 0.025 kips/ft<sup>2</sup> as its magnitude. Set **Sidewalk Width** to 1.5 ft for both sides of the roadway.
- ☛ Click **Generate**.

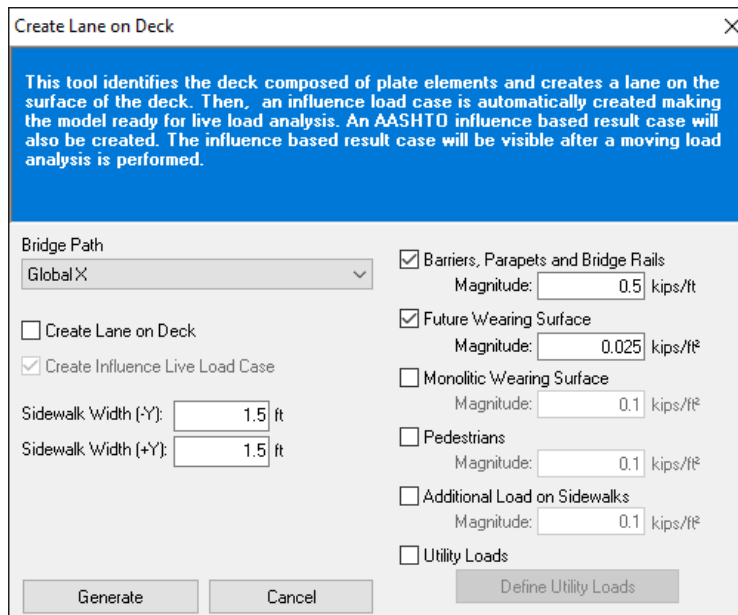

Define Loads On Deck

- ☛ Review the generated loads on the Graphics Window by clicking on the railing and future wearing surface load cases in the Load Cases Explorer.

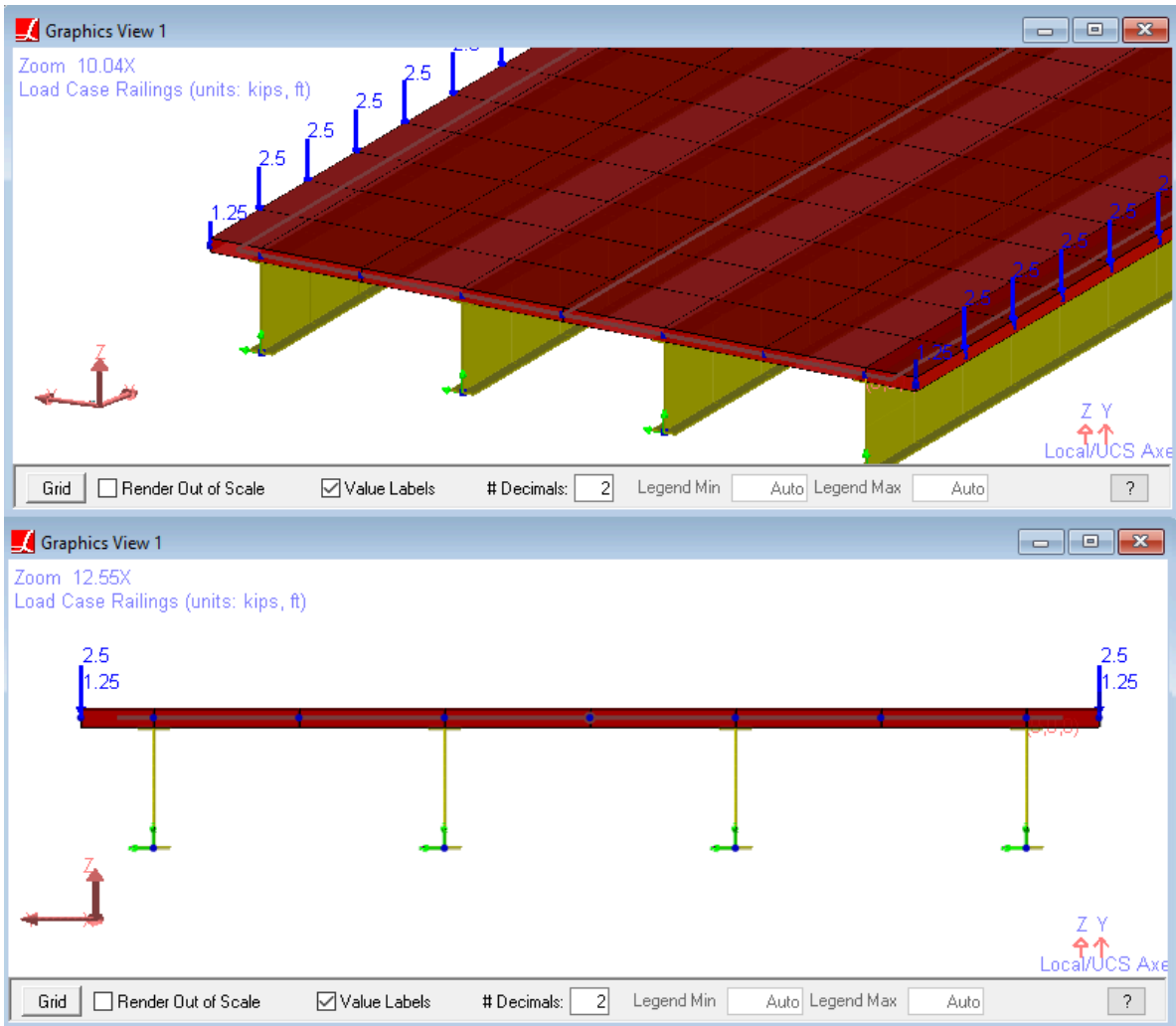

Railing Load



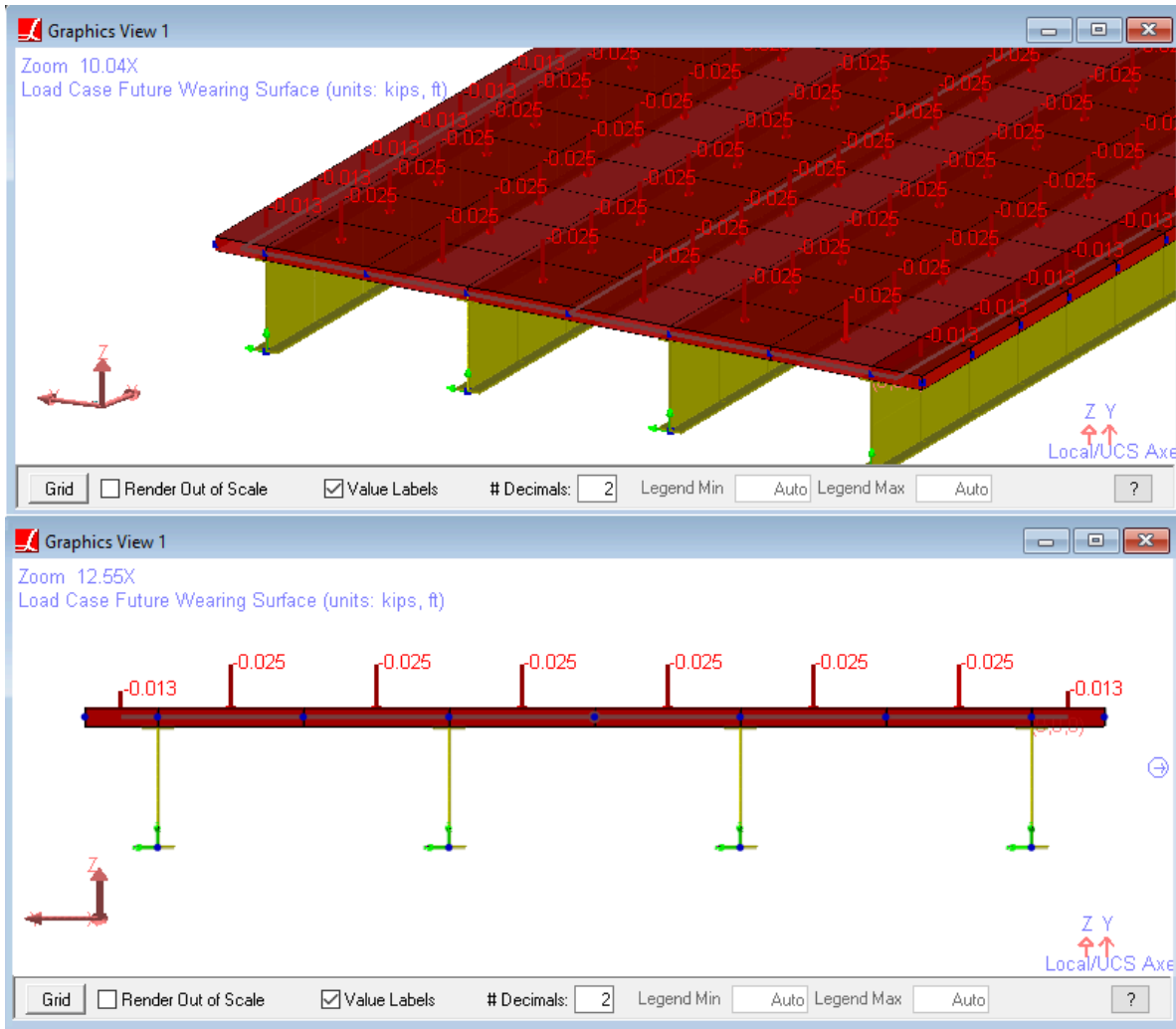

Future Wearing Surface Load

## Deck Weight and Wind Load

We will calculate the deck weight to be distributed across girders according to tributary deck widths. For Girders 1 and 4:

$$0.15 \text{ kip/ft}^3 \text{ (unit weight of concrete)} \times 9 \text{ ft (tributary deck width)} \times 0.75 \text{ ft (deck thickness)} = 1.0125 \text{ kip/ft}$$

And for Girders 2 and 3:

$$0.15 \text{ kip/ft}^3 \text{ (unit weight of concrete)} \times 12 \text{ ft (tributary deck width)} \times 0.75 \text{ ft (deck thickness)} = 1.3500 \text{ kip/ft}$$

We will also create two wind load cases to be applied to exterior girders with a depth of 60 in (5 ft). The magnitude of wind load is  $0.05 \text{ kip/ft}^2$ . Therefore the magnitude of wind load to be applied as line load is:

$$0.05 \text{ kip/ft}^2 \times 5 \text{ ft} = 0.25 \text{ kip/ft}$$

- ◆ In the Load Cases Explorer, add three load cases and rename them to “Deck Weight”, “Wind Load Pos”, and “Wind Load Neg”.

☛ Go to **Input Data** → **Load Cases & Combinations**.

In the Class column, you will see that the load classes of load cases which are generated by the tool are already set.

☛ Set the Load Class of Deck Weight to Dead Load.

☛ Set the Load Class of wind load cases to Wind Load on Structures.

	ID	Name	Analysis Type	Class	Status	Weight Factor X	Weight Factor Y	Weight Factor Z
1	1	Self Weight	Static	Dead Load	Active	0.0000	0.0000	-1.0000
2	2	Influence Coefficients	Moving	Live Load	Active	0.0000	0.0000	0.0000
3	3	Railings	Static	Dead Load of Nonstructural Components	Active	0.0000	0.0000	0.0000
4	4	Future Wearing Surface	Static	Dead Load of Wearing Surfaces and Utilities	Active	0.0000	0.0000	0.0000
5	5	Deck Weight	Static	Dead Load	Active	0.0000	0.0000	0.0000
6	6	Wind Load Pos	Static	Wind Load on Structures	Active	0.0000	0.0000	0.0000
7	7	Wind Load Neg	Static	Wind Load on Structures	Active	0.0000	0.0000	0.0000
8								

Show Only Selected Objects

#### Load Classes

☛ In the Structure Groups Explorer, click on the Girders folder and choose **Select (Unselect everything else)** from the action menu.

☛ Using the Graphics Tools, **Hide Unselected** objects and change view to the Top Plane.

Now, we will define deck weight and wind loads graphically.

☛ In Load Cases Explorer, click on Deck Weight load case to activate it.

☛ Go to **Draw** → **Loads** → **Member Loads**

You will see the Model Data Explorer on the right.

☛ Enter data to apply a **uniform load** of **-1.0125 kip/ft** in **Global Z** direction and drag window around the first and last girders.

☛ Change magnitude of the force to **-1.35 kip/ft** and drag window around the second and third girders.

☛ Click **Done**.

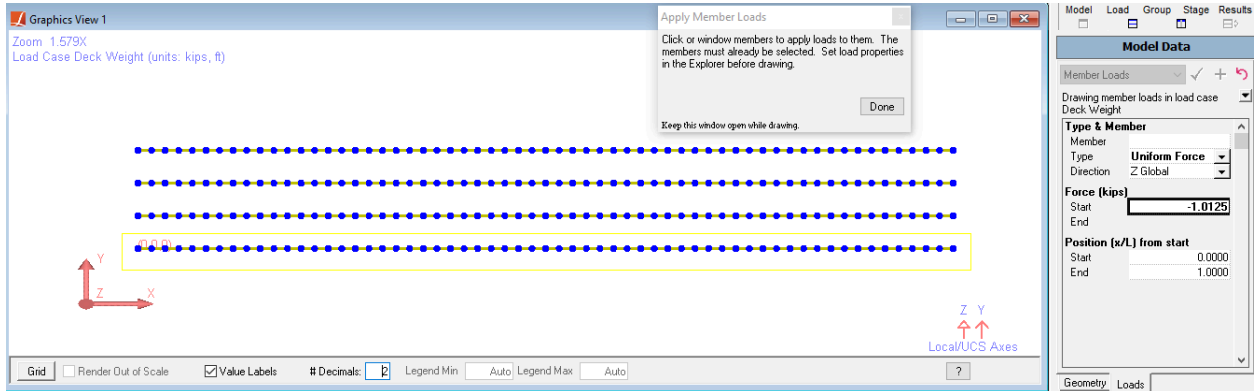

Draw Loads

- ☛ Apply Wind Load Pos only to Girder 1 (bottom girder in Top View) and Wind Load Neg only to Girder 4 (top girder in Top View) in a similar manner. This time the member load will be **0.25 kip/ft** and **-0.25 kip/ft** respectively in **Y Projection** direction.

## Construction Stages and Steps

Now we are ready to set up the staged construction stages and steps. Construction activities are broken down into stages, which each represent a day of construction, and steps which are analysis steps.

- ☛ Click the side-by-side “Show Two Explorers” button in the panel above the open explorer. It is below the **Group** and **Stage** buttons.
- ☛ Change the left-hand explorer to the Construction Stages Explorer by clicking the upper **Stage** button above the explorers. Change the right-hand explorer to the Structure Groups Explorer by clicking the **Group** button in the lower row.

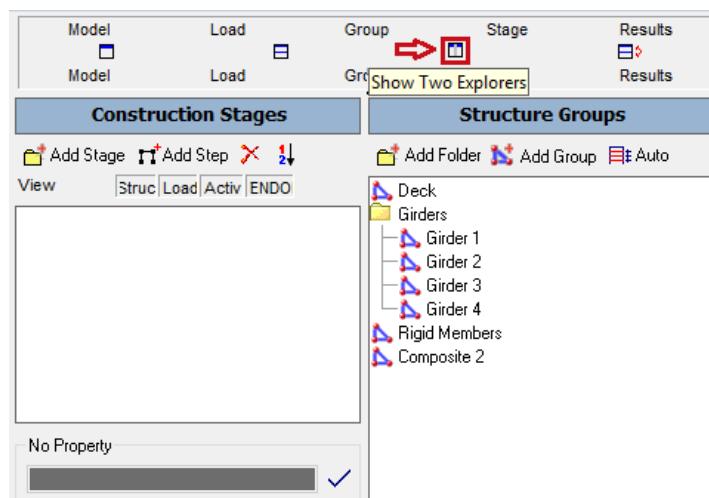

Stages and Groups Explorers Side-by-Side

In this example, we will have six construction stages.

- ☛ Create a new Stage by clicking the **Add Stage** button in the Construction Stages Explorer.

You will see a new Stage and a new Step created.

- Click **Add Step** in the Construction Stages Explorer to add a second step in this first construction stage.
- Using **Add Stage** and **Add Step** buttons, create the configuration that you see on the left hand side of the below figure.

It is also possible to rename construction stages and steps by a right-click.

- Rename the stages and steps as you see on the right hand side of the below figure.

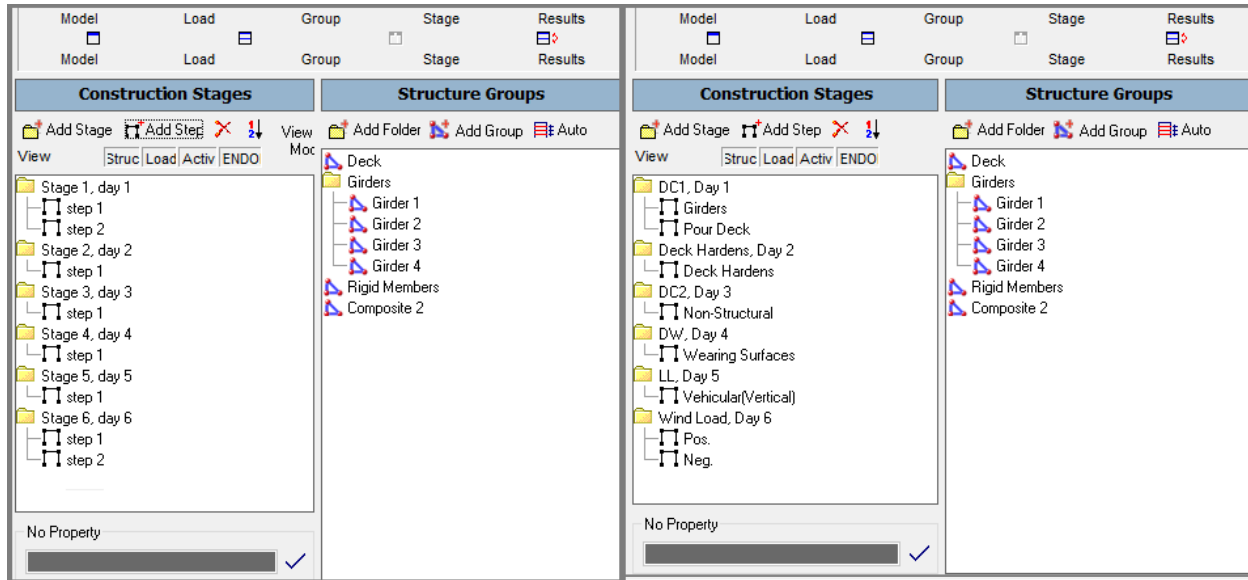

Construction Stages and Steps

The structure groups are put into steps to indicate the order in which the members should be constructed. All Structure Groups that are contained in a Step will be constructed at the same time. In this example, we will construct all girders at the first step.

- Drag the Girders folder from the Structure Groups Explorer into the Construction Stages Explorer, onto the **DC1's Girders** Step.
- Drag the structure group named Rigid Members from the Structure Groups Explorer onto the same construction step.
- Drag the structure group named **Deck** from the Structure Groups Explorer into the Construction Stages Explorer, onto the **Deck Hardens** Step.

In addition to constructing, we will also load the structure within Construction Stages.

- Change the right-hand explorer to the Load Cases Explorer by clicking the **Load** button in the lower row.

We will instruct LARSA 4D to include the self-weight of members as they are constructed.

- Drag the **Self Weight** load case by holding the blue arrow and drop it into **Girders** construction step.
- Similarly, drag the **Deck Weight** load case to **Pour Deck** construction step.

Since we apply Deck Weight in the DC1 Stage, we will set the Deck group just to gain stiffness at Deck Hardens Step.

☛ Right-click **Deck** structure group and select **Stiffness Only**.

☛ Add the remaining loads to be applied at the composite state as you can see in the below figure.

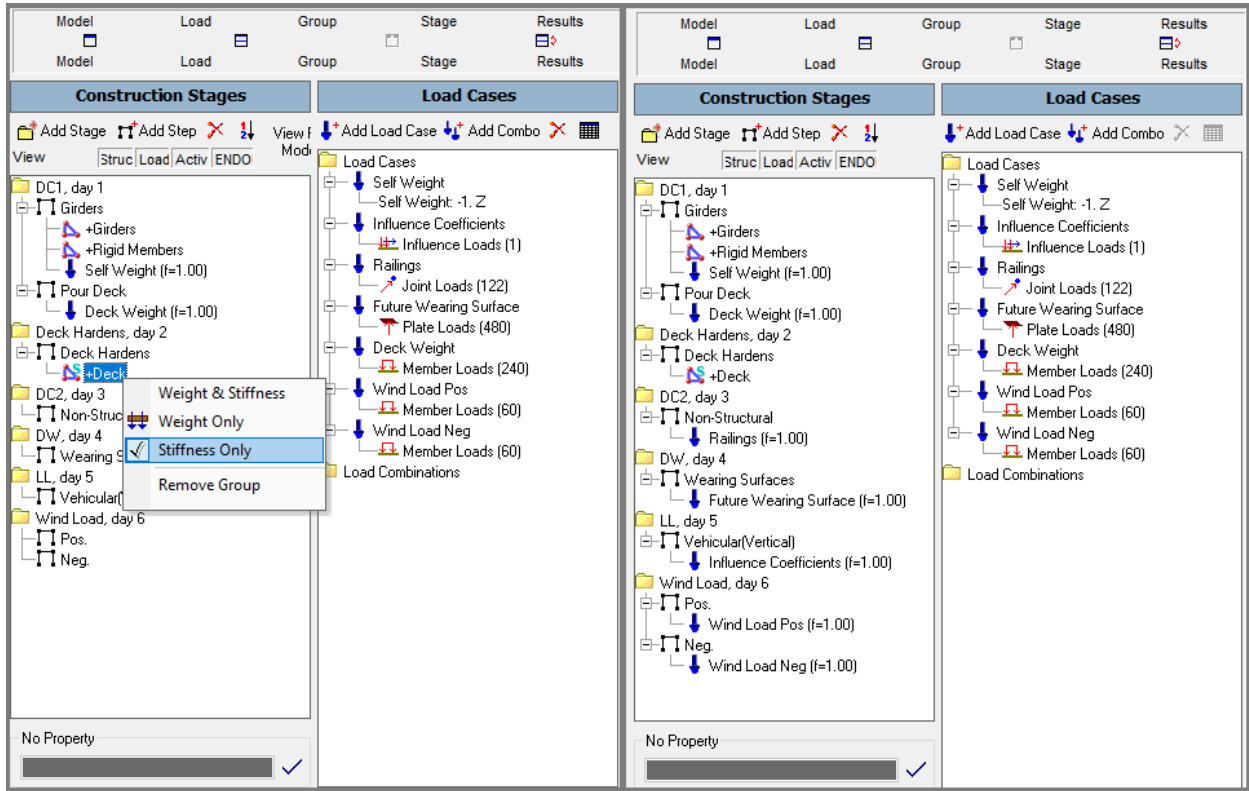

Construction Loads

### Construction Attributes

In LARSA 4D, each Construction (or analysis) Step has default construction attributes such as Nonlinear Static as the default Analysis Type.

We need to modify the analysis type of the Vehicular (Vertical) step in order to run Influence Based Live Load Analysis at that step.

☛ Right-click *Vehicular (Vertical)* step and choose **Properties**.

☛ In Construction Attributes window, set the analysis type to **Static Moving Load/Influence**.

**Construction Attributes**

---

**LL (Day 5): Vehicular (Vertical)**

---

Construct (Activate) Elements in this Step
  Deconstruct (Inactivate) Elements in this Step

---

**Segmental Construction Method**

**Cast in Place**  
 No corrections are made on joint coordinates.  
 This is the default construction method.

**Hinged Cast**  
 Newly assembled joints take the deformation of the last joint in the previously assembled segment.

**Matched Cast**  
 Newly assembled joints are placed along the tangent of the previous segment such that the original length of the segment is preserved.  
 This option applies only to segmental construction.

---

Auto-remove loads prior to next step
 
 Analysis Type: Static Moving Load/Influence
 Impact Factor: 1

---

Construction Attributes

You will see on the left hand side of the Analysis type, there is an option *Auto-remove loads prior to next step* which is used for the temporary loads within Construction Stages.

- ☛ Check this box for the construction attributes of wind load cases.
- ☛ Enable complete rendering and left click the steps one by one in order to visualize the construction sequence.

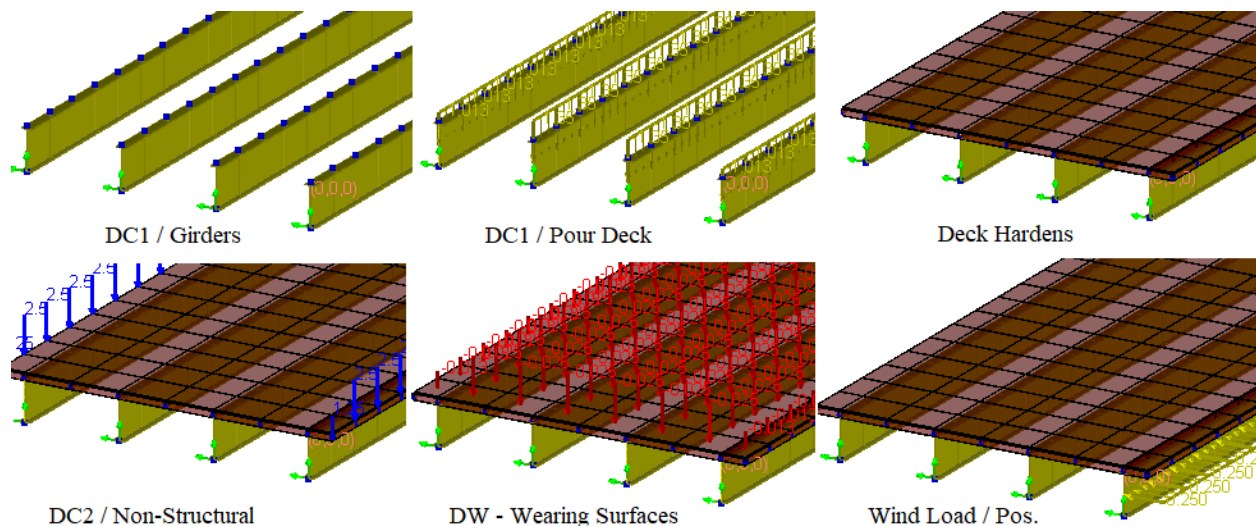

Construction Sequence

- Click **View Full Model** button to reset the graphical view to show all elements, regardless of whether they have been constructed or not.

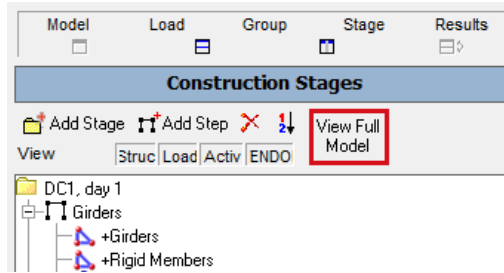

The View Full Model Button

## Include Time Effect on Modulus

LARSA 4D's Time-Dependent Staged Construction Analysis is a more advanced version of the Staged Construction Analysis that includes time-dependent effects including the effect on concrete elastic modulus, creep, shrinkage, steel relaxation for tendons, and the effects of superimposed loads. In this training, we will only include the time effect on concrete elastic modulus.

Before setting the material properties, we choose which time-dependent effects to include in the analysis.

- Go to **Analysis** → **Time Dependent Analysis Options**.
- Uncheck all other options and check the **Include Time Effect on Modulus** checkbox.
- Click **OK** to close the window.

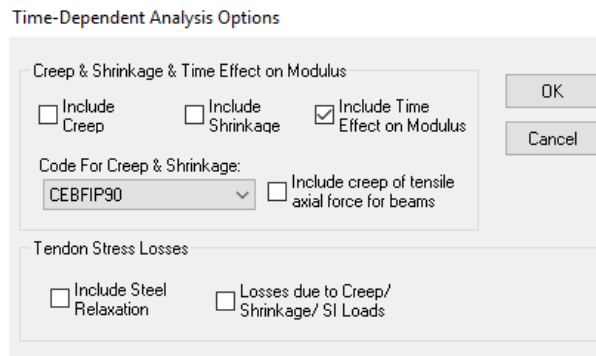

Time-Dependent Analysis Options

For the Time-Dependent Staged Construction Analysis, the day of each stage (which we will set) impacts the material properties of the members and shells. Additionally, a casting day must also be set for each concrete member undergoing time-dependent effects. The age of each concrete member is the difference between its casting day and the day of the stage.

To illustrate how the casting day can be set, we will set the casting day of deck concrete to Day 1 using the spreadsheets.

- Go to **Input Data** → **Geometry** and change to **Shells** tab.
- Click the column header for the Casting column to select the entire column.

- ☛ In the spreadsheet edit tool in the toolbar enter 1, then click the checkmark to apply the change to the selected cells.
- ☛ Close the spreadsheet.
- ☛ Go to **Input Data** → **Construction Stages** and modify the Construction Day of LL and Wind Load stages as 100 and 101.

Now, we will first indicate which material in the model is subject to time-dependent behavior. By default, no material is subject to time effects. We will create a “Material Time Effect definition” and assign it to the deck concrete material to indicate that it will undergo time effects.

*Material Time Effect definitions may also be assigned to section definitions in the project if it is more convenient, but a member should not have a Material Time Effect definition on both its material and section.*

- ☛ Go to **Input Data** → **Properties**.

Note that the modulus of elasticity of concrete (Fc\_4) material is 3,605,000 lb/in<sup>2</sup>.

- ☛ Change to the **Material Time Effects** tab.
- ☛ Add one row to the spreadsheet and change the name of the material time effect definition to “Concrete Time”.

	Name	Creep Factor	Shrinkage Factor	Relaxation Factor	Exponent of Creep Development Eqn.	Constant in Shrinkage Development Eqn.	Temp. Adjusted Concrete	Steel Relaxation Type	Assigned
1	Concrete Time	1.0000	1.0000	1.0000	0.3000	350.0000	No	Improved(Class 2)	No
2									

Material Time Effects

- ☛ Right-click the row and choose **Edit Curve: Time VS Modulus of Elasticity**.

Per AASHTO LRFD Bridge Design Specifications, “For transient loads assumed applied to the short-term composite section, the concrete deck area shall be transformed by using the short-term modular ratio, n. For permanent loads assumed applied to the long-term composite section, the concrete deck area shall be transformed by using the long-term modular ratio, 3n”.

For permanent loads:

$$\text{Long-term modular ratio} = E_{\text{girder}} / (E_{\text{deck}}/3) = 3n \text{ where } E_{\text{deck}}/3 = 3,605,000/3 = 1,201,666.67 \text{ lb/in}^2$$

For short-duration loads:

$$\text{Short-term modular ratio} = E_{\text{girder}} / E_{\text{deck}} = n \text{ where } E_{\text{deck}} = 3,605,000 \text{ lb/in}^2$$

- ☛ Enter time versus modulus of elasticity curve data accordingly.



Time VS Modulus of Elasticity: Concrete Time

Coefficients \ Graph

	Age (Days)	Modulus of Elasticity (lb/in <sup>2</sup> )
1	1.0000	1.2017e6
2	99.0000	1.2017e6
3	100.0000	3.6050e6
4	200.0000	3.6050e6
5		

Time VS Modulus of Elasticity Coefficients

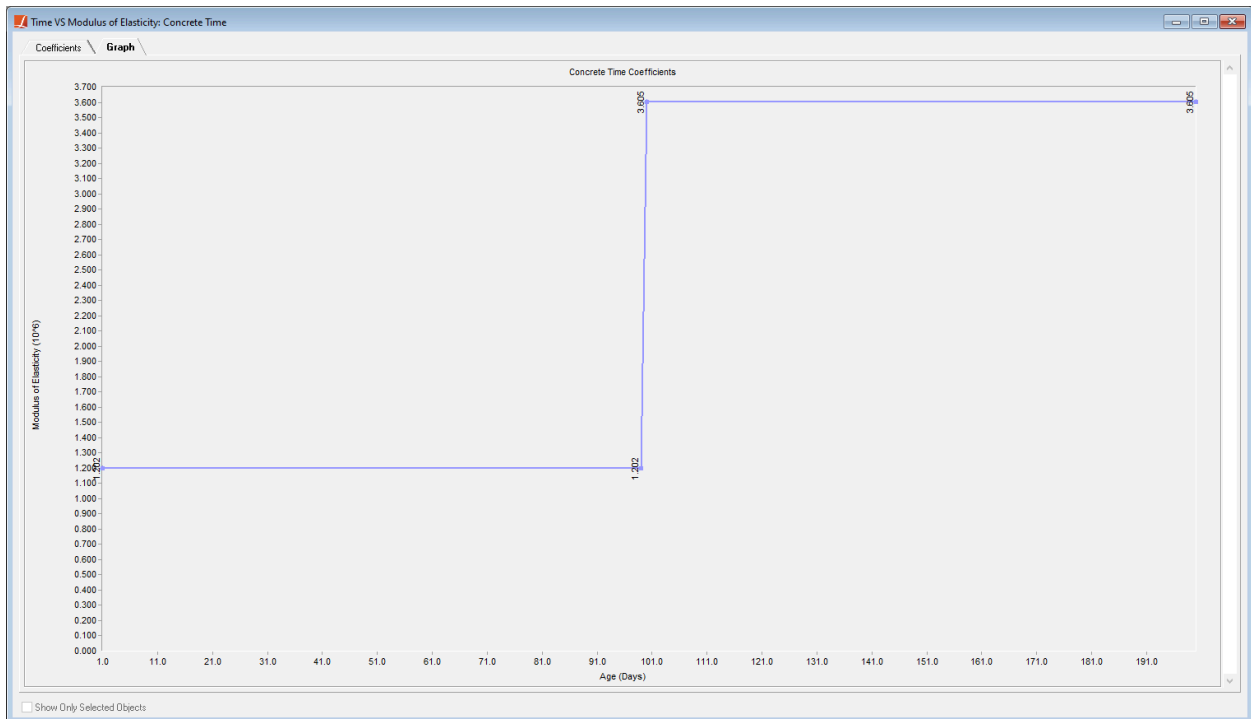

Time VS Modulus of Elasticity Graph

- ☛ Close the spreadsheet and switch to **Materials** → **More Properties** tab.
- ☛ For the Fc\_4 material, change the Material Time Effect column to “Concrete Time” and close the spreadsheet.

## Running the Analysis

We can now run the Time-Dependent Staged Construction Analysis. The analysis will compute the state of the structure after each construction step accounting for the effect of time on concrete modulus.

- ☛ Go to **Analysis** → **Staged Construction Analysis**.

- ☛ Choose the **Time-Dependent** analysis type.
- ☛ Open the **Construction Stages** options tab, and set Ending Construction Stage to the last stage, Day 101: Wind Load.

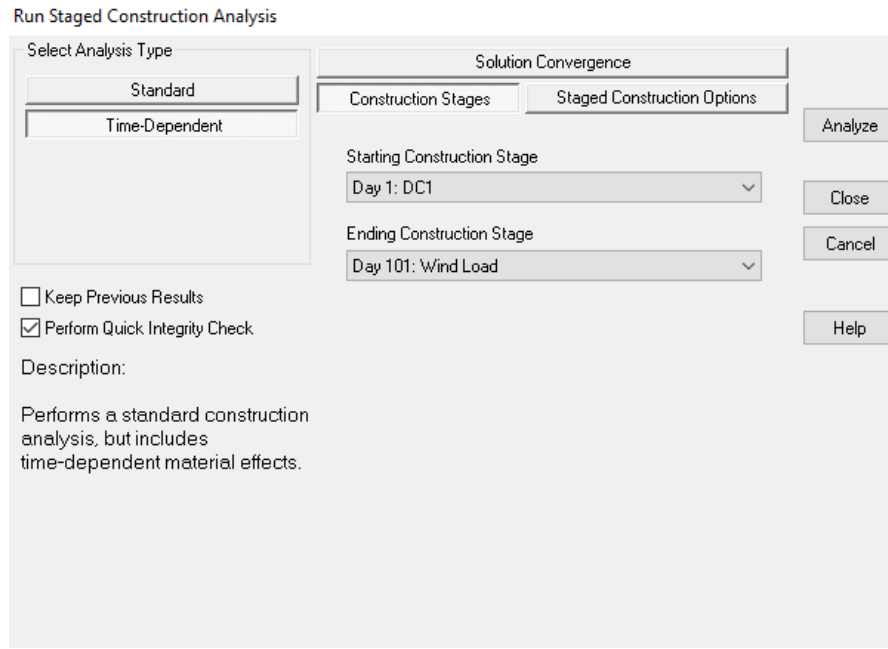

Staged Construction Analysis Options

- ☛ Click **Analyze**.
- ☛ After the analysis completes, close the analysis window.

## Analysis Results

The Analysis Results Explorer will open automatically. This time the result cases are in the Construction Stages group. Inside this group there will be a group for each construction stage, and inside that the results for each construction step.

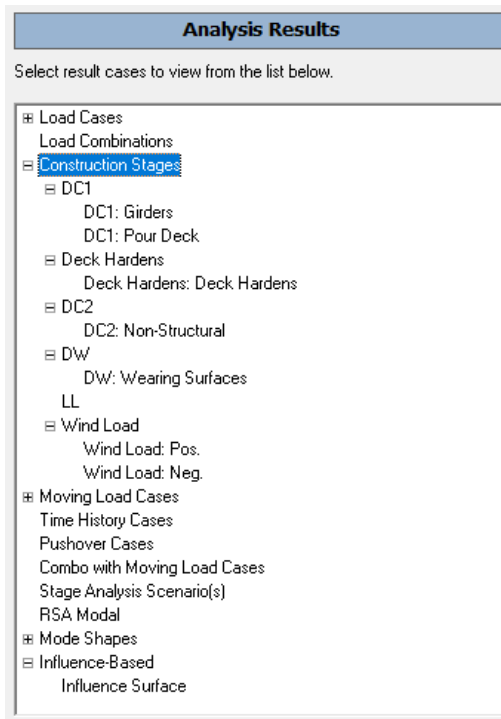

Staged Construction Results

☛ In the Graphics Window, unselect all elements and select the outer support at Pier 1 location (joint 191) using the graphical selection tools.

☛ In the result groups, right-click the result case DC1: Girders and select Joint Reactions.

You will just see the reactions of the selected support.

☛ Holding the **Ctrl** key on your keyboard, click all construction steps in the Analysis Results window.

	Joint	Result Case	Force X (kips)	Force Y (kips)	Force Z (kips)	Moment X (kips-ft)	Moment Y (kips-ft)	Moment Z (kips-ft)
1	191	DC1: Girders	0.0000	0.0000	24.1330	0.0000	0.0000	0.0000
2	191	DC1: Pour Deck	0.0000	0.0000	135.4955	0.0000	0.0000	0.0000
3	191	Deck Hardens: Deck Hardens	0.0000	0.0000	135.4955	0.0000	0.0000	0.0000
4	191	DC2: Non-Structural	-20.5161	-7.4401	198.8751	0.0000	0.0000	0.0000
5	191	DW: Wearing Surfaces	-16.5268	-6.2096	218.2604	0.0000	0.0000	0.0000
6	191	Wind Load: Pos.	-18.9222	-13.9229	219.1288	0.0000	0.0000	0.0000
7	191	Wind Load: Neg.	-16.0794	-1.2701	222.4156	0.0000	0.0000	0.0000

Results of Multiple Steps

The default results displayed are always the cumulative results. It represents step by step accumulating effects on the structure.

- At the top of the spreadsheet, turn on **Incremental Results**.

	Joint	Result Case	Force X (kips)	Force Y (kips)	Force Z (kips)	Moment X (kips-ft)	Moment Y (kips-ft)	Moment Z (kips-ft)
1	191	DC1: Girders	0.0000	0.0000	24.1330	0.0000	0.0000	0.0000
2	191	DC1: Pour Deck	0.0000	0.0000	111.3625	0.0000	0.0000	0.0000
3	191	Deck Hardens: Deck Hardens	0.0000	0.0000	0.0000	0.0000	0.0000	0.0000
4	191	DC2: Non-Structural	-20.5161	-7.4401	63.3797	0.0000	0.0000	0.0000
5	191	DW: Wearing Surfaces	3.9893	1.2306	19.3853	0.0000	0.0000	0.0000
6	191	Wind Load: Pos.	-2.3953	-7.7133	0.8683	0.0000	0.0000	0.0000
7	191	Wind Load: Neg.	0.4474	4.9395	4.1551	0.0000	0.0000	0.0000

Incremental Results

The results that you see in the spreadsheet represent the incremental effects on the structure from various construction steps.

Since we have set load classes to corresponding load cases, we will also be able to extract class-based results.

- Now change **View Full Cumulative Results** to **Extract Dead Load of Nonstructural Components**.

	Joint	Result Case	Force X (kips)	Force Y (kips)	Force Z (kips)	Moment X (kips-ft)	Moment Y (kips-ft)	Moment Z (kips-ft)
1	191	DC1: Girders	0.0000	0.0000	0.0000	0.0000	0.0000	0.0000
2	191	DC1: Pour Deck	0.0000	0.0000	0.0000	0.0000	0.0000	0.0000
3	191	Deck Hardens: Deck Hardens	0.0000	0.0000	0.0000	0.0000	0.0000	0.0000
4	191	DC2: Non-Structural	-20.5161	-7.4401	63.3797	0.0000	0.0000	0.0000
5	191	DW: Wearing Surfaces	-20.5161	-7.4401	63.3797	0.0000	0.0000	0.0000
6	191	Wind Load: Pos.	-20.5161	-7.4401	63.3797	0.0000	0.0000	0.0000
7	191	Wind Load: Neg.	-20.5161	-7.4401	63.3797	0.0000	0.0000	0.0000

Class-Based Results

The results that you see in the spreadsheet represent the cumulative effects coming from the dead load of nonstructural components on the structure for various construction steps. Recall that we only have the Railing load as dead load of nonstructural components (load class) and it is applied at DC2: Non-Structural step within construction stages. This is why we see the effects of the Railing Load on the structure starting from that step, and the cumulative results do not change afterwards.

For this example, the incremental effects of DC2: Non-Structural construction step and the contribution from dead load of nonstructural components class are the same. If there were more than one load case with different load classes applied in a single construction step, these results would be different from each other.

## Compound Element Forces

The bridge design codes, such as AASHTO LRFD, require the values of the resultant section forces acting at the center of gravity of the cross section. In LARSA 4D, Compound Element Forces tool is used to determine the section forces at the center of gravity, in a girder or composite section modeled not as a single beam, but as a mesh of shells or as a combination of beams and shells.

In the preceding chapter of the manual, we have illustrated the use of Compound Element Forces by slicing the structure at a particular position.

The structure can also be sliced in a number of stations along the Global Coordinate System or the Bridge Path to be used for computation of the compound element forces. At each station, a section plane is created laterally perpendicular to the bridge path and perpendicular to the XY plane. This plane passes through elements in the model representing the bridge girder or the composite section.

The analysis results present the forces and moments acting at each node of each element through which the section plane passes. The forces at the nodes of each element are then proportioned to determine their values at the location of the intersection with the section plane. This is done for each element intersection at every station along the length of the girder. The forces and moments at each intersection point in the section plane are then used to compute the equivalent forces and moments at the center of gravity of the cross section.

Now, we will review section forces in Girder 2 at certain intervals for non-composite and composite states.

Before using the tool, user needs to select the interested geometry graphically or the corresponding structure group in the Structure Groups Explorer and also the interested result case in the Analysis Result Explorer.

- ☛ In the Structure Groups Explorer, select “Composite 2” structure group.
- ☛ In the Analysis Results Explorer, activate “DC1: Pour Deck” result case under Construction Stages heading.
- ☛ Go to **Results** → **Compound Element Forces**.

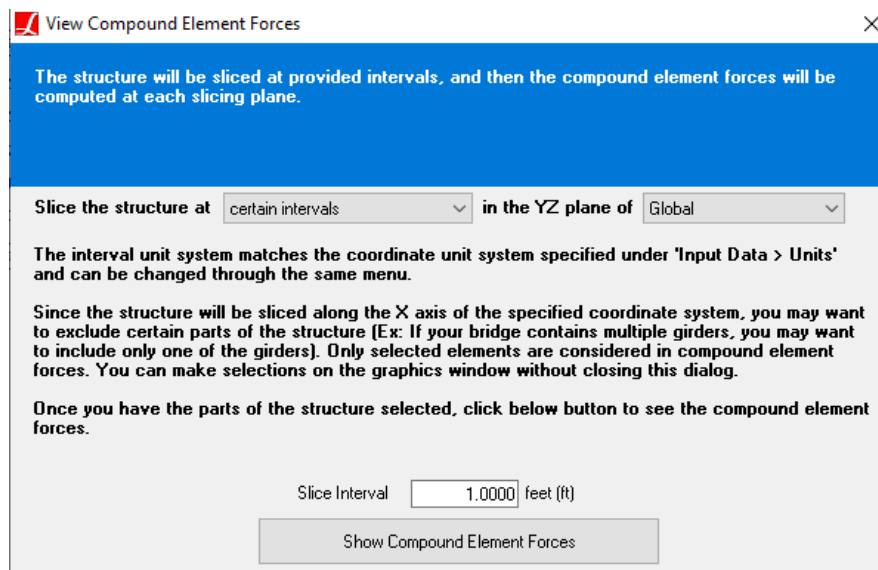

Compound Element Forces Tool

- ☛ Enter 1.0 ft for the slice interval.

Click **Show Compound Element Forces** button.

The screenshot displays two windows from the LARSA 4D software. The top window, titled "Graphics View 1", shows a bridge model with a blue line representing the deck and green dots representing elements. A coordinate system is visible with Y and Z axes. The bottom window, titled "Compound Element Forces", contains a spreadsheet with the following data:

	Elements	Path	Station (ft)	Result Case	Centroid X (ft)	Centroid Y (ft)	Centroid Z (ft)	Force X (kips)	Force Y (kips)	Force Z (kips)	Moment X (kips-ft)	Moment Y (kips-ft)	Moment Z (kips-ft)
1	M41	Global X Axis	0.0000	DC1: Pour Deck	0.0000	12.0000	-2.8750	0.0000	0.0000	62.7960	0.0000	0.0000	0.0000
2	M41	Global X Axis	1.0000	DC1: Pour Deck	0.0000	12.0000	-2.8750	0.0000	0.0000	61.2266	0.0000	58.8725	0.0000
3	M41	Global X Axis	2.0000	DC1: Pour Deck	0.0000	12.0000	-2.8750	0.0000	0.0000	59.6572	0.0000	117.7449	0.0000
4	M41	Global X Axis	3.0000	DC1: Pour Deck	0.0000	12.0000	-2.8750	0.0000	0.0000	58.0877	0.0000	176.6174	0.0000
5	M41	Global X Axis	4.0000	DC1: Pour Deck	0.0000	12.0000	-2.8750	0.0000	0.0000	56.5183	0.0000	235.4898	0.0000
6	M41	Global X Axis	5.0000	DC1: Pour Deck	0.0000	12.0000	-2.8750	0.0000	0.0000	54.9489	0.0000	294.3623	0.0000
7	M42	Global X Axis	6.0000	DC1: Pour Deck	0.0000	12.0000	-2.8750	0.0000	0.0000	53.3795	0.0000	345.3877	0.0000
8	M42	Global X Axis	7.0000	DC1: Pour Deck	0.0000	12.0000	-2.8750	0.0000	0.0000	51.8101	0.0000	396.4130	0.0000
9	M42	Global X Axis	8.0000	DC1: Pour Deck	0.0000	12.0000	-2.8750	0.0000	0.0000	50.2407	0.0000	447.4384	0.0000

Non-composite State Section Forces

Even though the “Composite 2” structure group including the deck shell elements is selected, if we look at the cells under Elements column, we see that since deck has not gained its stiffness in “DC1: Pour Deck” step yet, the section forces are reported along the non-composite girder elements.

Without closing the spreadsheet, activate “DC2: Non-Structural” result case in the Analysis Results Explorer.

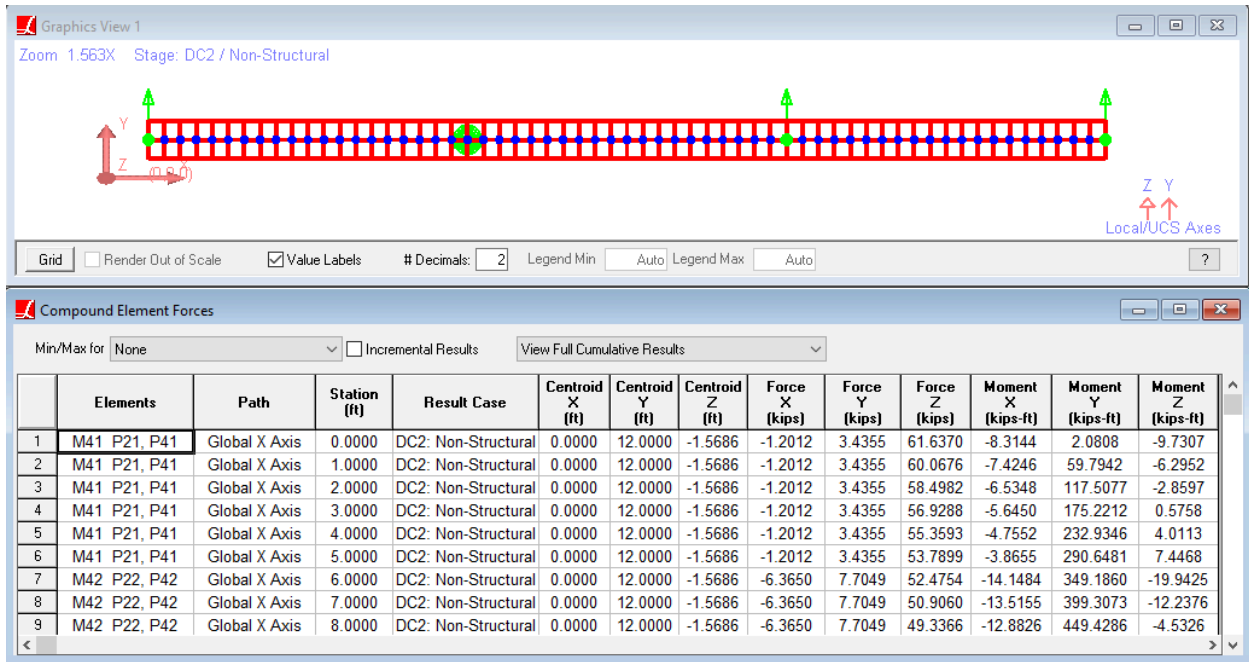

Composite State Section Forces

For composite state, deck shell elements are also included in the cross section when reporting the section forces.

The center of gravity is computed by the program for the respective cross sections at every station. If the section is a composite section with steel girder and the concrete deck like our current model, composite centroid is computed by transforming deck concrete into an equivalent amount of steel also taking into account the time effect on concrete elastic modulus.

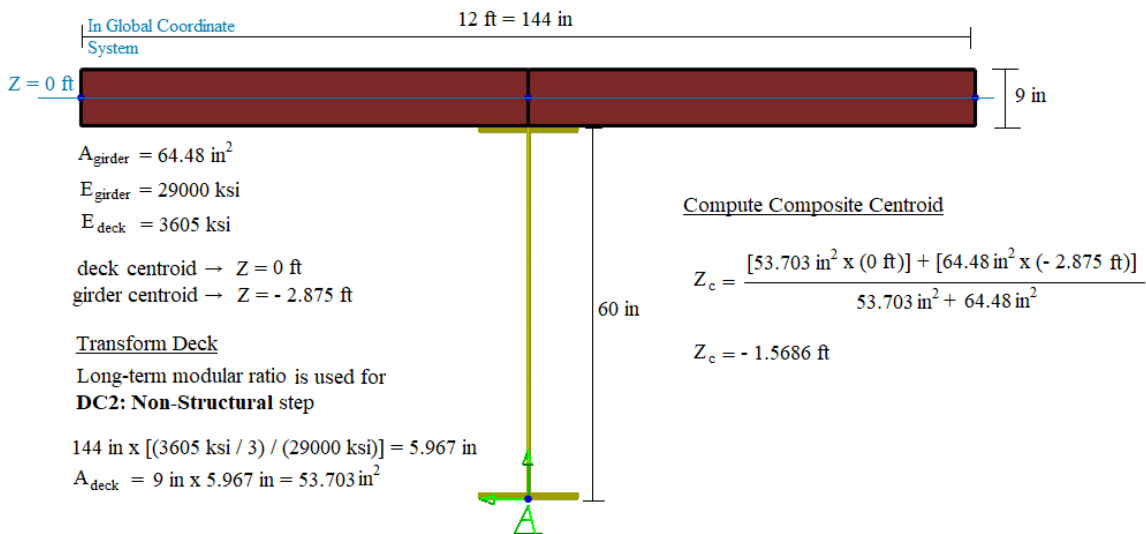

Centroid of Composite Section

## A Final Note on Code-Based Stresses

In LARSA, Member Stresses are the internal stresses along the length of the member, in member local directions. Reported normal stresses at stress recovery points include axial, longitudinal bending and lateral bending stresses (*If exists, also the self-equilibrating stresses*):

$$\text{Normal Stress} = Fx/\text{Area} + z*M_y/I_{yy} + y*M_z/I_{zz}$$

Shell stresses are the internal stresses of shells, either at the center of the shell, in the spreadsheet named Shell Stresses on Center, or at the joint locations, in the spreadsheet named Shell Stresses at Joints.

For most cases, the member or shell stress analysis results reported in result spreadsheets are not compatible with the code-based stresses required for design. For example, AASHTO LRFD requires the stress parameter  $f_{bu}$  which is the flange longitudinal bending stress calculated without consideration of flange lateral bending.

For the calculation of  $f_{bu}$  parameter, instead of reading stresses directly from stress result spreadsheets, the design moment at the section due to strong-axis bending should be extracted using the Compound Element Forces tool and computed using the section properties of the cross-section under consideration.

---

For More Information, please refer to the following documentation.

- Structure Groups Explorer in *LARSA 4D User's Manual*.
- Loads in *LARSA 4D Reference Manual*.
- Staged Construction Analysis in *LARSA 4D Reference Manual*.
- Compound Element Forces in *LARSA 4D Reference Manual*.



# Index

- AASHTO LRFD, 49
- bearings, 19
- break members, 19
- bridge example,
- combinations, 49
- compound element forces, 71
- construction loads, 71
- dead load, 43
- deformed model, 45
- drawing members, 19
- example,
- generation tool, 19
- groups, 71
- influence line example, 49
- joints spreadsheet, 19
- linear static analysis, 45
- live load example, 49
- refining a model, 19
- results, 45
- scale factor, 45
- self weight, 43
- staged construction analysis example, 71
- steel bridge,
- structure groups
  - Staged Construction Analysis, 71
  - Structure Groups, 39
- temporary loads, 71
- training manual,